

# Kitchen portraits

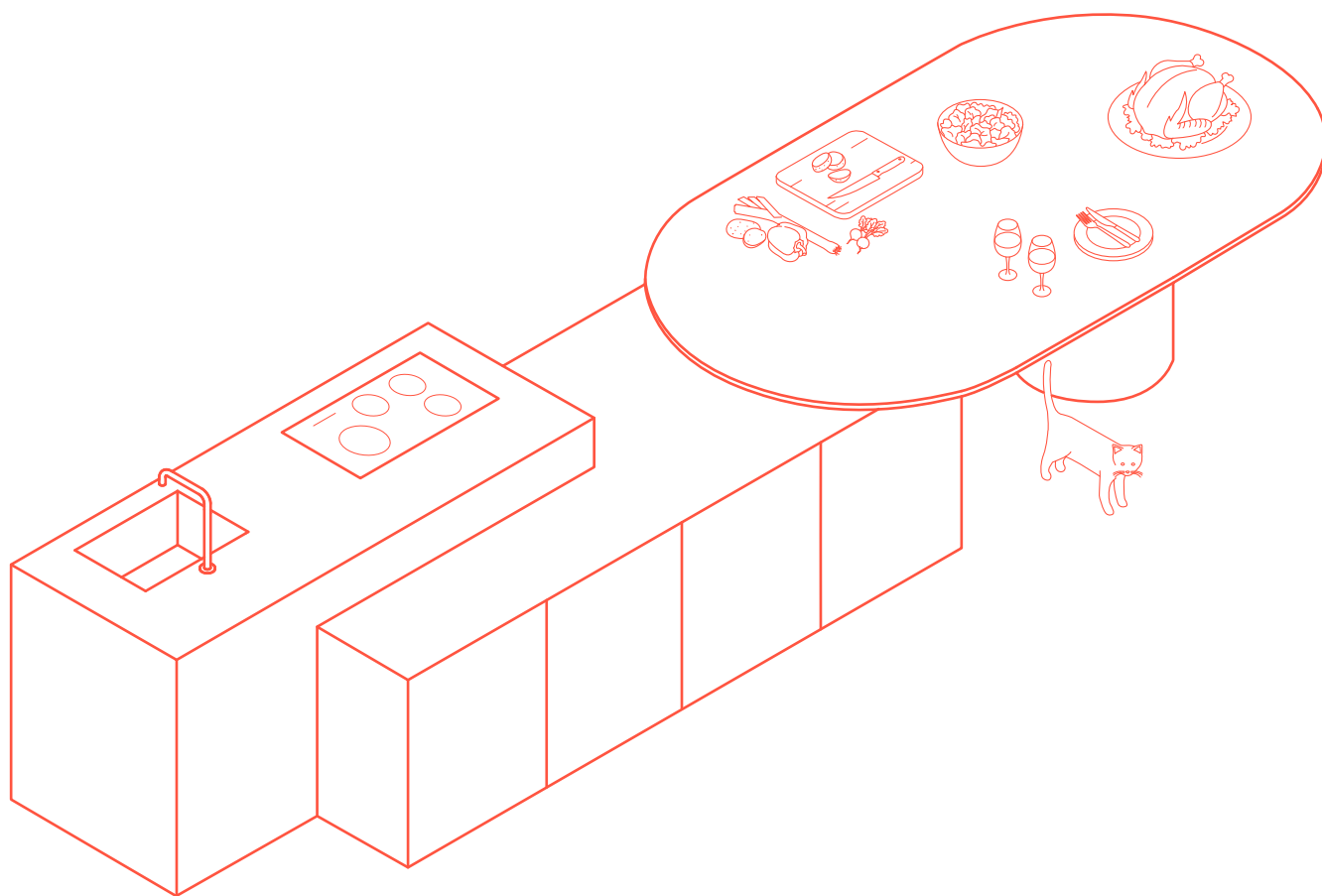

**MESON'S**



**Benvenuti in cucina**  
**Welcome to the kitchen**

**MESON'S**

**IT** La cucina racconta chi la vive.  
Progettarla bene significa  
trovare un equilibrio autentico  
tra forma e funzione.  
Da sessant'anni, questo  
è il nostro lavoro.  
Benvenuti in cucina.

**EN** The kitchen tells the story  
of those who live in it.  
Designing it well means  
finding an authentic balance  
between form and function.  
We have been doing this  
for sixty years.  
Welcome to the kitchen.

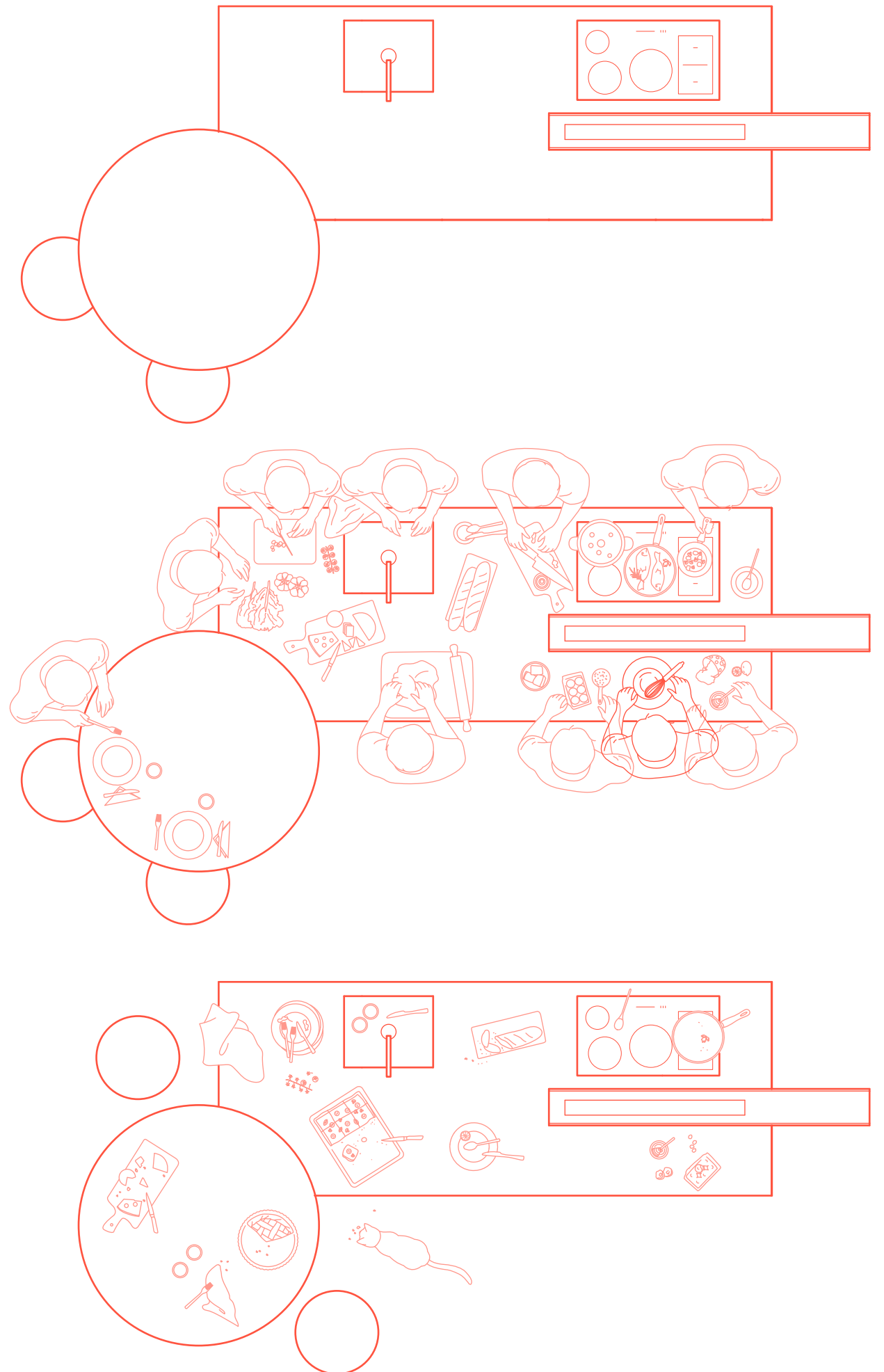

**IT Dal 1964 viviamo  
l'evoluzione della cucina,  
con una visione sempre innovativa  
e una passione  
che si rinnova ogni giorno,  
progetto dopo progetto.**

**EN With our incessantly  
innovative outlook and daily  
rekindled passion, project  
after project, we have been  
experiencing the evolution  
of the kitchen since 1964.**

**Una storia che guarda al futuro  
/ A history that looks to the future**

1980



**IT Meson's nasce in una realtà industriale solida, capace di rinnovarsi nel tempo senza perdere coerenza. È stata tra le prime aziende italiane a introdurre le cucine all'americana, espressione di modernità, progresso ed emancipazione. Fondata nel 1964 e per un periodo parte del gruppo Zanussi, l'azienda porta un nome disegnato da Bob Noorda, designer di fama internazionale, capace di sintetizzare visione globale e identità italiana.**



1990



2010

**EN Meson's was born within a solid industrial reality, capable of renewing itself over time without losing consistency. It was among the first Italian companies to introduce American-style kitchens, an expression of modernity, progress, and liberation. Founded in 1964 - and for a while part of the Zanussi group - the company bears a name designed by Bob Noorda, an internationally renowned designer capable of synthesising global vision and Italian identity.**

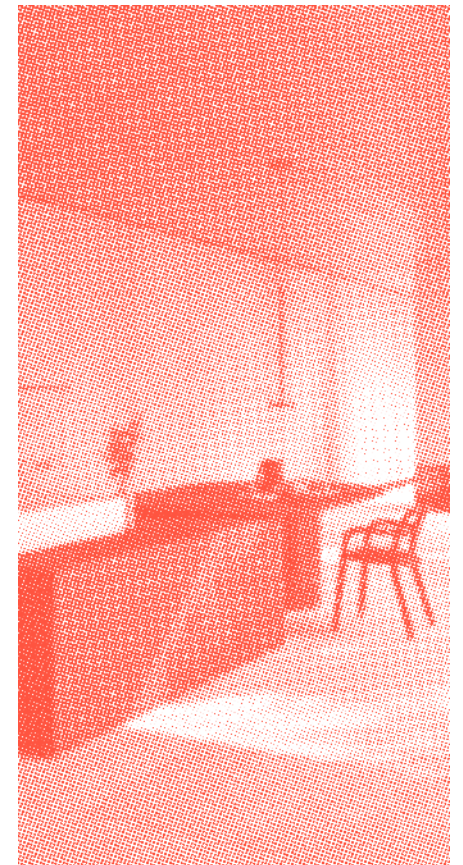

2026

**IT** Ogni cucina è un progetto su misura. La precisione dell'industria e la cura dell'artigianato per progetti ad alto indice di personalizzazione.

**EN** Every kitchen is a bespoke project. Industrial precision and craftsmanship care for projects with a high level of personalisation.

## La cucina sartoriale / The tailored kitchen

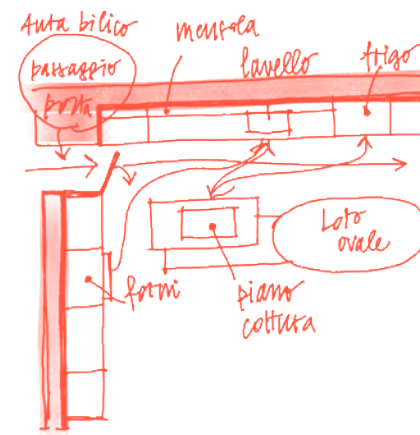

**IT** Il progetto Meson's nasce dall'incontro tra precisione industriale e competenza artigianale. Un approccio che consente un alto livello di personalizzazione mantenendo standard qualitativi rigorosi. Dalla definizione dei mood estetici agli interventi a scala architettonica, dalla realizzazione di elementi fuori misura all'ottimizzazione di spazi e funzioni, ogni cucina è costruita sulle esigenze specifiche dello spazio e del progetto.

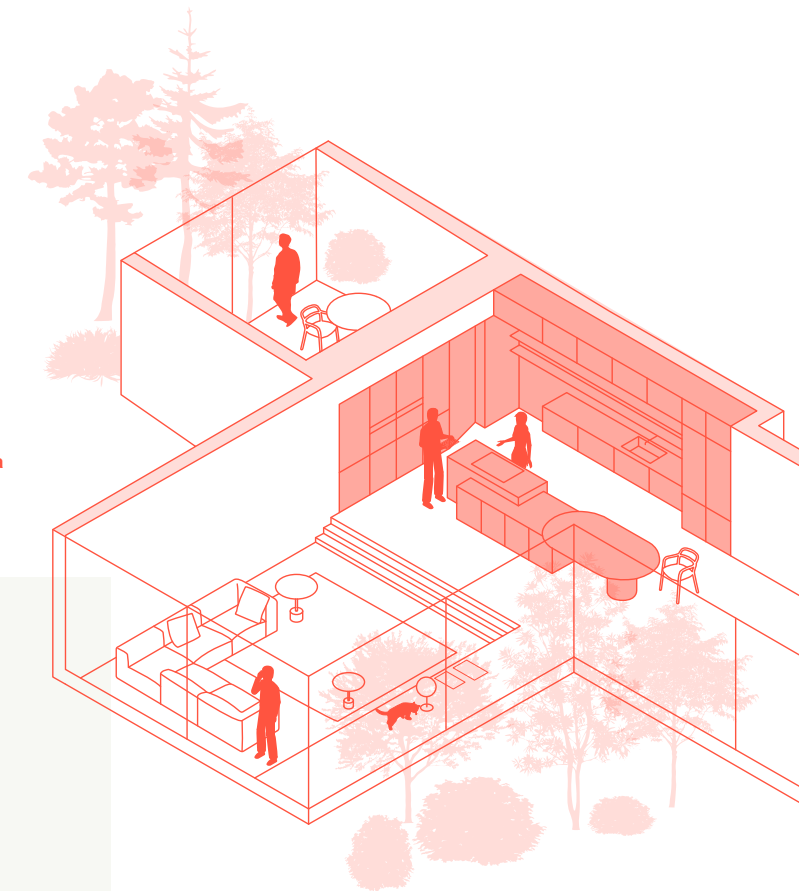

**EN** Meson's project is born from the encounter between industrial precision and artisanal expertise. An approach that allows for a high degree of customisation while maintaining rigorous quality standards. From the definition of aesthetic moods to architectural-scale interventions, from the creation of custom-sized elements to the optimisation of spaces and functions, every kitchen is built around the specific needs of the space and of the project.



**<sup>IT</sup> Progettare senza limiti.  
Sistemi aperti,  
linguaggio unico  
M2 e ME.**

**<sup>EN</sup> Limitless design.  
Open systems,  
a unique language  
M2 and ME.**

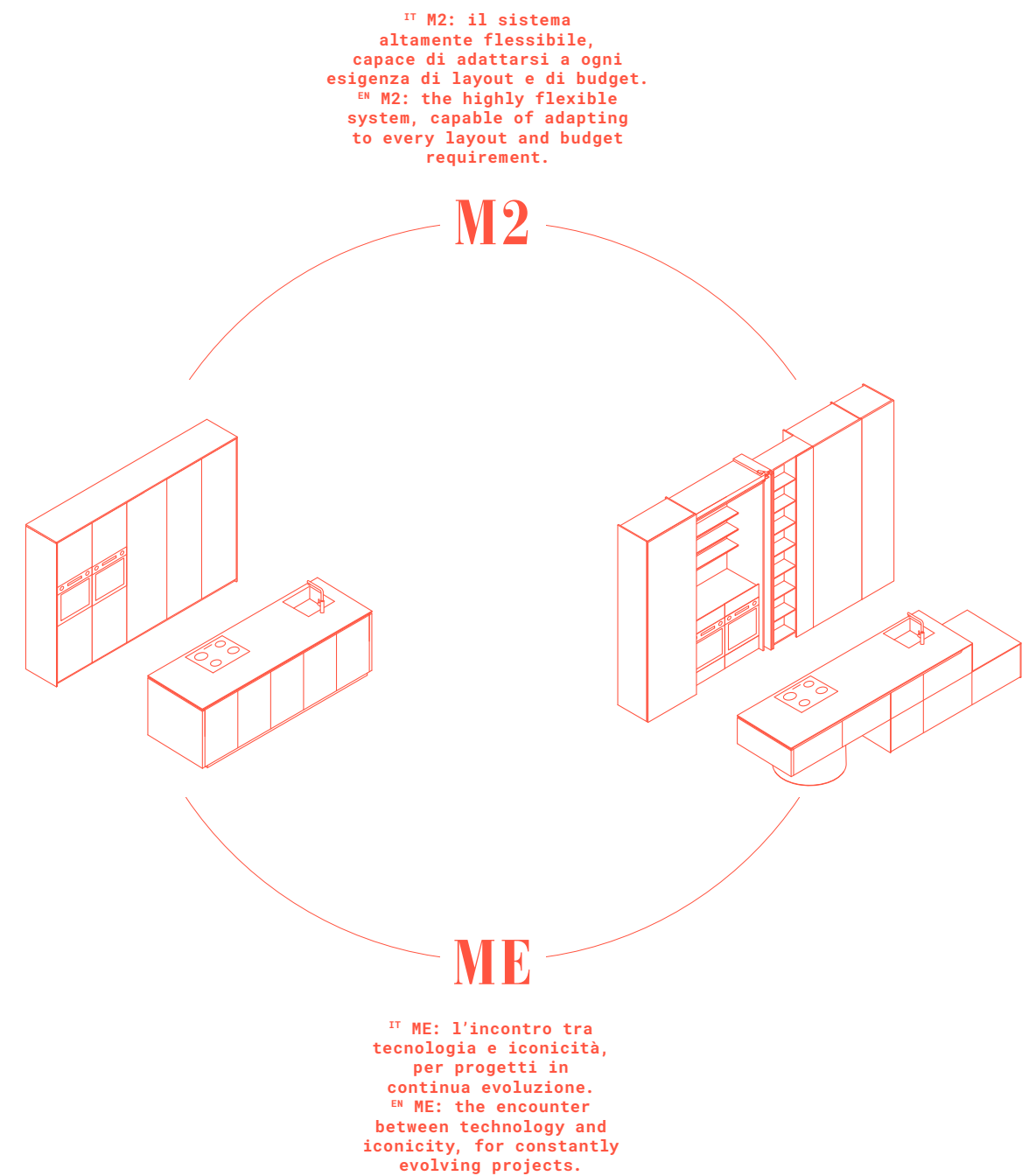

<sup>IT</sup> Insieme esprimono la vocazione progettuale di Meson's: sistemi diversi ma compatibili, pensati per dialogare come un insieme aperto e connesso, capace di offrire infinite combinazioni mantenendo coerenza formale e chiarezza di gamma. Una piattaforma flessibile per architetti e interior designer, un ecosistema progettuale completo.

<sup>EN</sup> Together they express Meson's design vocation: different but compatible systems, designed to communicate as an open and connected whole, capable of offering endless combinations while maintaining formal coherence and range clarity. A flexible platform for architects and interior designers. A complete design ecosystem.

**<sup>IT</sup> La materia come strumento di progetto. Una gamma ampia e selezionata di finiture per lavorare su atmosfere diverse e su più fasce di prezzo. Un approccio che consente di gestire il budget mantenendo coerenza progettuale e qualità del risultato.**

**<sup>EN</sup> Materials as a design tool. A wide and selected range of finishes to work on different atmospheres and to span multiple price brackets. An approach that allows for budget management while maintaining design coherence and quality of result.**



**IT Il design intelligente.  
Il dettaglio che non si vede  
è quello che fa la differenza.**

**EN Smart design  
The detail you cannot see  
is the one that makes  
the difference.**



**IT Le cucine Meson's sono il risultato di un processo continuo di perfezionamento fatto di dettagli costruttivi, soluzioni ergonomiche, accorgimenti tecnici che migliorano l'esperienza nel tempo. La tecnologia è integrata e funzionale: pensata per durare, non per stupire.**



**EN Meson's kitchens are the result of a continuous process of refinement made of construction details, ergonomic solutions, and technical features that improve the user's experience over time. Technology is integrated and functional: designed to last, not to impress.**

<sup>IT</sup> Ogni progetto nasce dall'equilibrio tra estetica, tecnologia e durabilità, con l'obiettivo di offrire il massimo valore possibile, nel rispetto delle diverse capacità di spesa, senza mai rinunciare alla qualità.

<sup>EN</sup> Every project is born from the balance between aesthetics, technology, and durability, and is aimed at offering the maximum possible value while respecting different spending capacities without ever compromising on quality.



**Benvenuti in cucina**  
**Welcome to the kitchen**

# Kitchen portraits

**MESON'S**

**La passione di progettisti e tecnici.  
La ricerca estetica e funzionale, la storia,  
la tecnologia e l'attenzione all'ambiente.  
Nelle collezioni ME e M2 c'è tutto  
questo. Uno stile unico che combina  
qualità, cura dei dettagli e  
l'inconfondibile gusto italiano.  
Questa è Meson's.  
Benvenuti nella galleria di famiglia.**

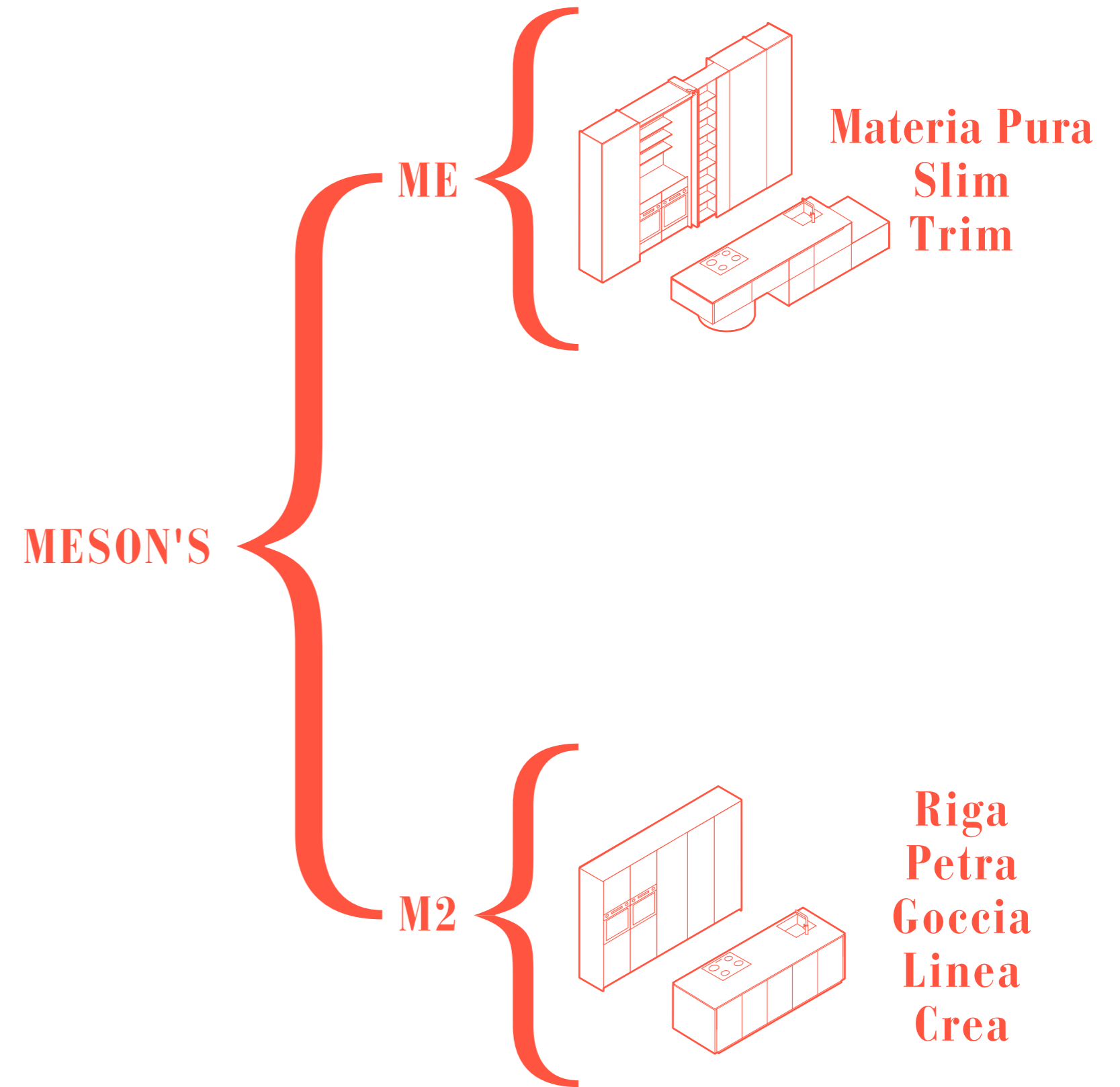

EM The passion of designers and technicians. Aesthetic and functional research, history, technology and attention to the environment. All of this is featured in the ME and M2 collections. A unique style which combines quality, attention to detail and undeniable Italian taste. This is Meson's. Welcome to the family gallery.

# Index

## ME

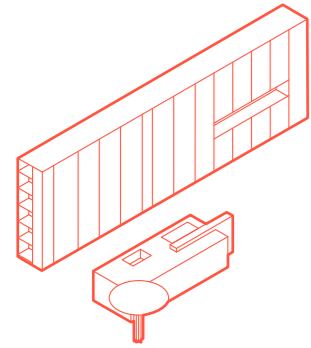

ME Materia Pura G  
p. 8

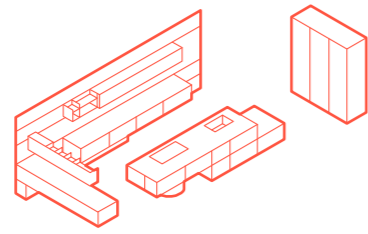

ME Materia Pura S  
p. 36

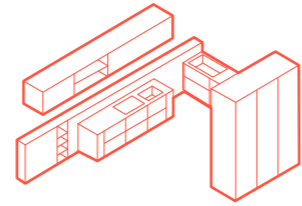

ME Trim  
p. 64

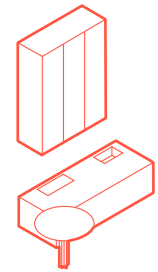

ME Materia Pura G  
p. 14

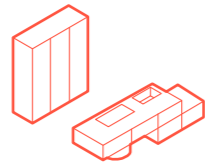

ME Materia Pura S  
p. 42

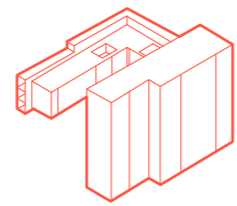

ME Trim  
p. 68

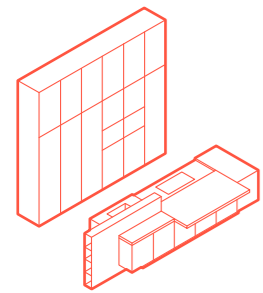

ME Materia Pura  
p. 22

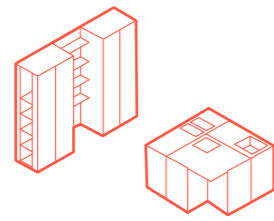

ME Slim  
p. 50

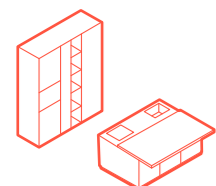

ME Materia Pura  
p. 28

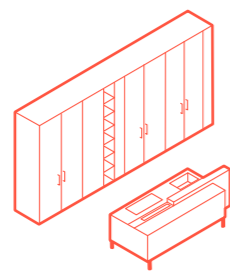

ME Slim  
p. 56

## M2

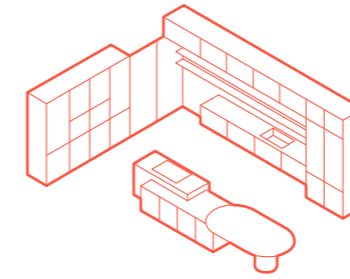

M2 Riga  
p. 76

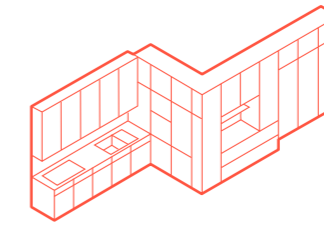

M2 Petra M  
p. 104

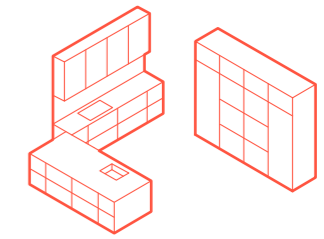

M2 Linea  
p. 128

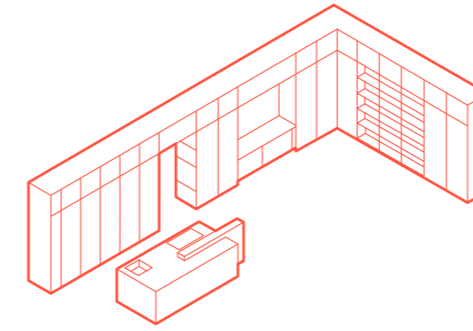

M2 Riga G  
p. 84

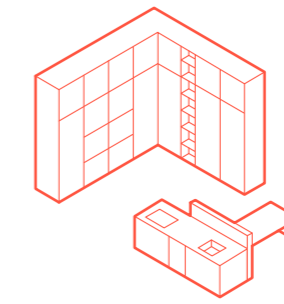

M2 Goccia  
p. 110

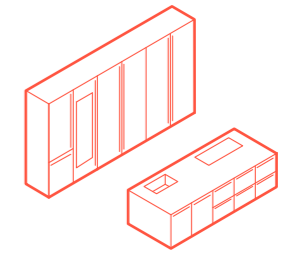

M2 Crea  
p. 134

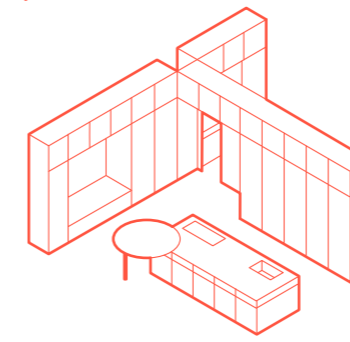

M2 Riga M  
p. 92

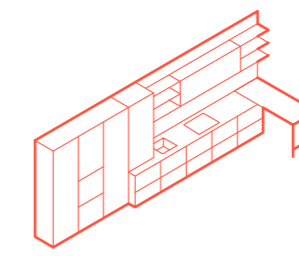

M2 Linea  
p. 116

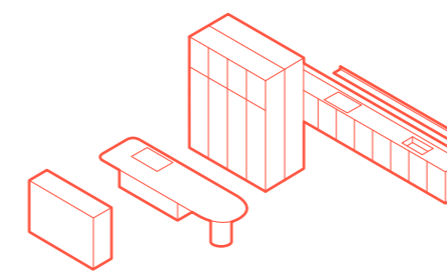

M2 Petra  
p. 98

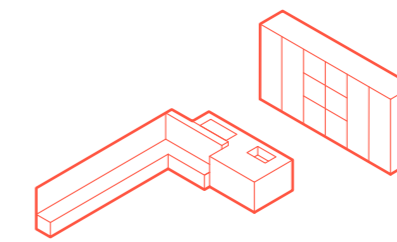

M2 Linea  
p. 122

# ME: Materia Pura Slim Trim

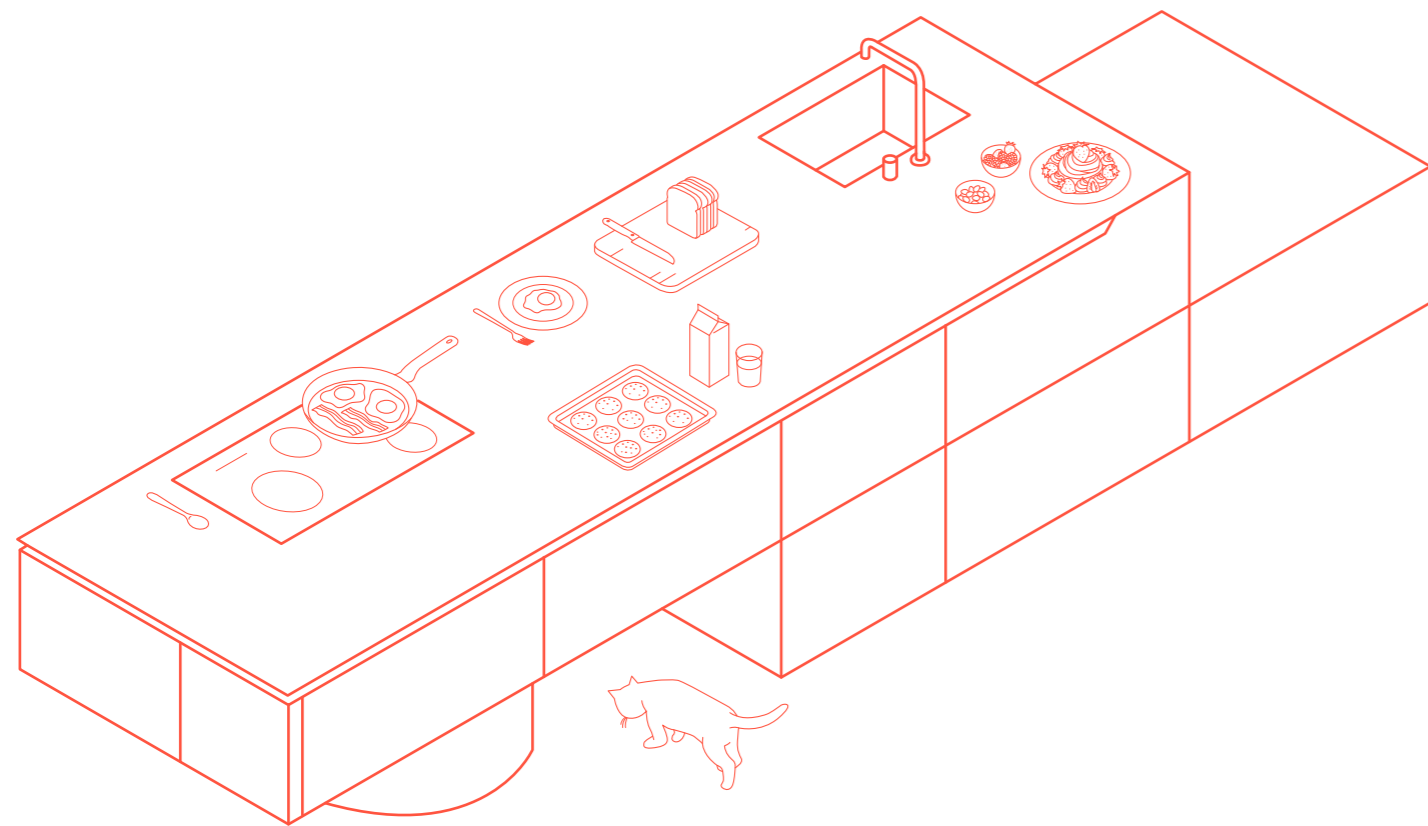

**ME Materia Pura**

p. 8

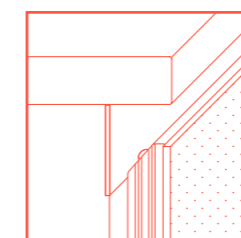

**ME Slim**

p. 50

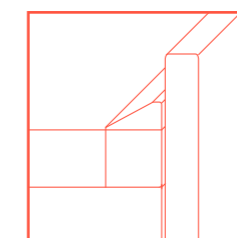

**ME Trim**

p. 64

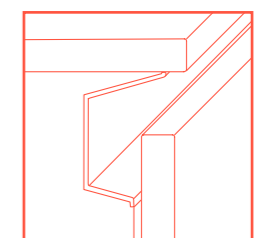

# ME Materia Pura G

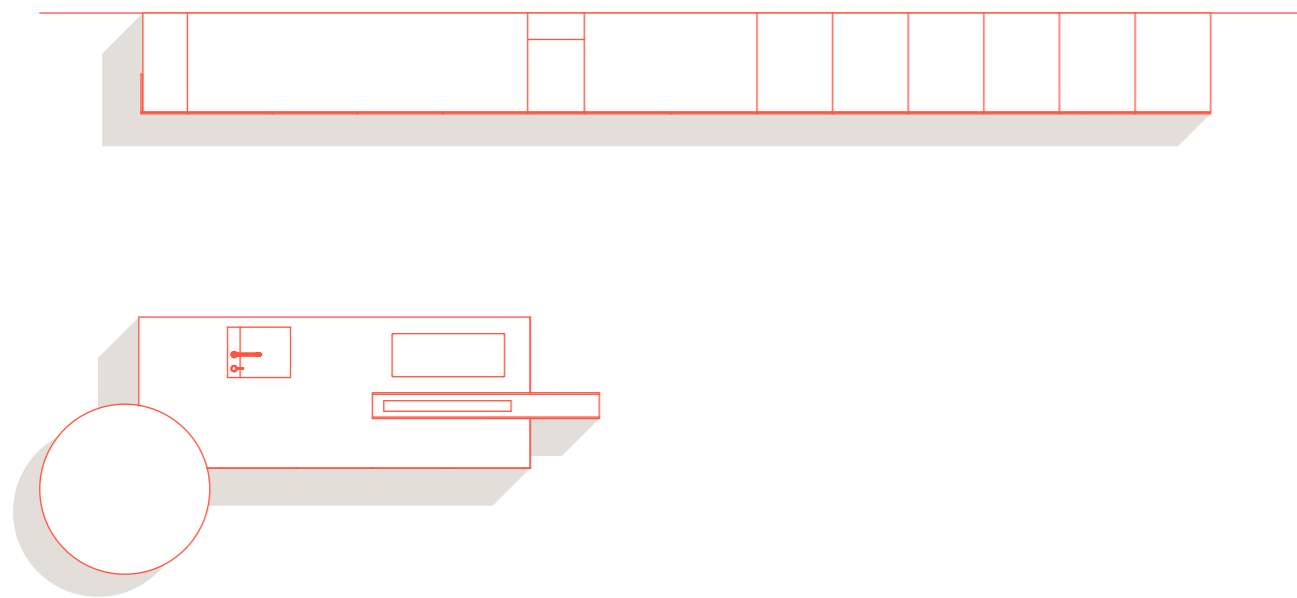

Vetro acidato Crema / Etched Crema glass

Laminam Gemini Pelle / Laminam Gemini Pelle

Vetro Fumè Bronzo / Smoked Bronzo glass

Laminam Cristallo Gold Rain / Laminam Cristallo Gold Rain

Essenza Premium Ambra / Essenza Premium Ambra Veneer



Vetro acidato Crema / Etched Crema glass

Laminam Gemini Pelle / Laminam Gemini Pelle

Vetro Fumè Bronzo / Smoked Bronzo glass

Laminam Cristallo Gold Rain / Laminam Cristallo Gold Rain

Essenza Premium Ambra / Essenza Premium Ambra Veneer





<sup>IT</sup> Linee leggere, contrasti sottili, accostamenti materici che dialogano con la luce. Una composizione che invita alla calma e all'ascolto, in cui ogni dettaglio restituisce equilibrio, ritmo e profondità. La cucina si fonde nello spazio con eleganza discreta, trasformandosi in luogo da abitare con naturalezza e intensità.

<sup>EN</sup> Light lines, subtle contrasts, material combinations that converse with light. A composition that invites calm and attentiveness, where every detail conveys balance, rhythm and depth. The kitchen blends seamlessly into the space with understated elegance, becoming a place to inhabit with natural ease and quiet intensity.



# Declinazioni

La composizione si ridisegna, senza perdere la propria essenza, in una nuova scala pensata per gli spazi dell'abitare contemporaneo. Tre declinazioni materiche danno vita a nuove visioni del progetto: variazioni di tono, luce e atmosfera che trasformano l'identità dello spazio.



EN The arrangement is redesigned without losing its essence, in a new scale designed for contemporary living spaces. Three material interpretations give life to new ways of viewing the project: variations in tone, light, and atmosphere that transform the identity of the space.



17 Isola con top e ante in vetro acidato Crema, tavolo in ceramica Laminam Gemini Pelle, sorretto da gambone in vetro Fumè Bronzo. Le colonne con ante in Laminam Cristallo Gold Rain celano al loro interno la zona operativa attrezzata con forni e boiserie Lampo.



18 Island with worktop and doors in etched Crema glass, table in Laminam Gemini Pelle ceramic, supported by a Smoked Bronzo glass leg. Tall units with Cristallo Gold Rain Laminam ceramic doors conceal the operational area equipped with ovens and a Lampo boiserie.



<sup>17</sup> Isola con top e ante in Laminam Terra di Pompei, tavolo in Essenza Premium Cenere, sostenuto dal gambone in vetro Fumè Bronzo. Le colonne con ante in Laccato Ossidato Satinato Piombo nascondono al loro interno la zona operativa e la boiserie Lampo in Laminam Terra di Pompei con ripiani in metallo Nero.

<sup>18</sup> Island with worktop and doors in Laminam Terra di Pompei ceramic, table in Essenza Premium Cenere veneer, supported by a Bronzo Fumè glass leg. Tall units in Piombo Satinato Oxidized Lacquer conceal the functional core and the Lampo boiserie in Laminam Terra di Pompei, complete with Black metal shelves.



<sup>IT</sup> Isola con top in Laminam Cardoso Nero fiammato e ante in Metallo Peltro, tavolo realizzato nello stesso Laminam e sorretto da un gambone cilindrico in vetro Fumè, Colonne in Essenza Premium Scavata Ossidiana nascondono la zona operativa con boiserie Lampo in Laminam Cardoso Nero fiammato, arricchita da ripiani in metallo Nero.

<sup>EN</sup> Island with Laminam Cardoso Nero fiammato ceramic worktop and precious Peltro Metal doors, matching table, supported by a minimalist cylindrical leg in Fumè smoked glass. Tall units in Essenza Premium Scavata Ossidiana veneer enclose the working area and the Lampo boiserie in Laminam Cardoso Nero with Black metal shelves.



# ME Materia Pura

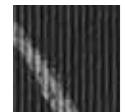
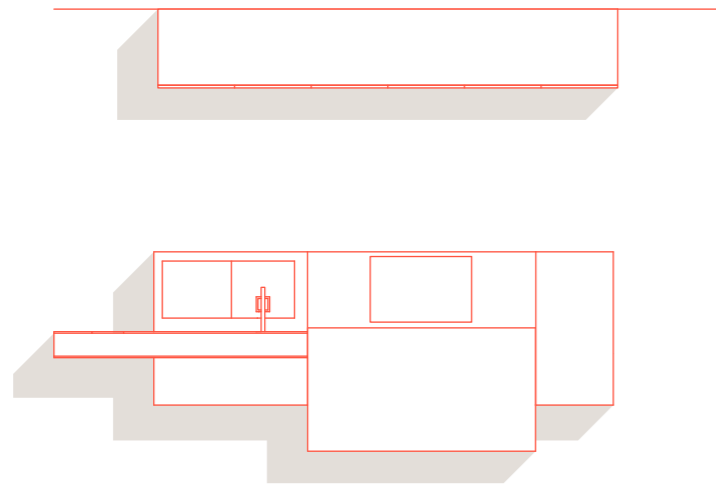

Laminam Calacatta Black Rain



Laminam Calacatta Black



Vetro acidato Antracite



Essenza Premium Ossidiana



Laminam Inside Terra di Matera



Laminam Calacatta Black Rain



Laminam Calacatta Black



Vetro acidato Antracite, Essenza Premium Ossidiana / Etched Antracite glass, Essenza Premium Ossidiana veneer



Laminam Inside Terra di Matera





<sup>IT</sup> Geometrie piene, superfici profonde, armonie materiche che giocano con la luce. Una composizione intensa e misurata, dove ogni elemento parla di equilibrio e trasformazione. La cucina diventa gesto architettonico, luogo da vivere con consapevolezza, forza e sobrietà.

<sup>EN</sup> Bold geometries, deep surfaces, material harmonies that play with light. An intense and measured composition, where every element speaks of balance and transformation. The kitchen becomes an architectural gesture, a space to be experienced with awareness, strength, and quiet elegance.



# Declinazioni

Il progetto si declina in configurazioni diverse, tra variazioni di scala, proporzioni e materiali. Dalla composizione più ampia alla soluzione più compatta, superfici e finiture ne interpretano il carattere con espressioni sempre nuove. Un progetto che scolpisce lo spazio con misura, senza mai perdere la sua identità.



EN The project is expressed in different configurations, through variations in scale, proportions, and materials. From the largest arrangement to the most compact solution, surfaces and finishes interpret its character with ever-new expressions. A project that carves the space with poise, without ever losing its identity.



<sup>17</sup> Isola su basamento con ante in Laminam Calacatta Black Rain, top e ampio piano scorrevole in Laminam Calacatta Black. Colonne Slim a sviluppo orizzontale in Essenza Premium Tessuto Ossidiana, con vani a giorno coordinati.

<sup>18</sup> Island, set on a plinth, featuring doors in Laminam Calacatta Black Rain, worktop and sliding worktop in Laminam Calacatta Black. Slim tall units in Essenza Premium Tessuto Ossidiana veneer, completed with matching open compartments.



<sup>17</sup> Isola su basamento con ante e top in vetro Sfumato Peonia, piano scorrevole in Essenza Premium Cenere. Colonne in Essenza Premium Scavata Cenere, con vani a giorno coordinati.

<sup>18</sup> Island, set on a plinth, featuring doors and worktop in Peonia Gradient glass, sliding top in Essenza Premium Cenere. Tall units in Essenza Premium Scavata Cenere veneer with matching open compartments.



<sup>17</sup> Isola su basamento con ante e top in vetro acidato Vaniglia, piano scorrevole in Laminam Travertino Bianco. Colonne in Laccato Ossidato Graffiato Rame, con vani a giorno abbinati.



<sup>18</sup> Island, set on a plinth, featuring doors and worktop in Etched Vaniglia Glass, sliding top in Laminam Travertino Bianco. Tall units in Rame Graffiato Oxidized Lacquer with matching open compartments.

# ME Materia Pura S

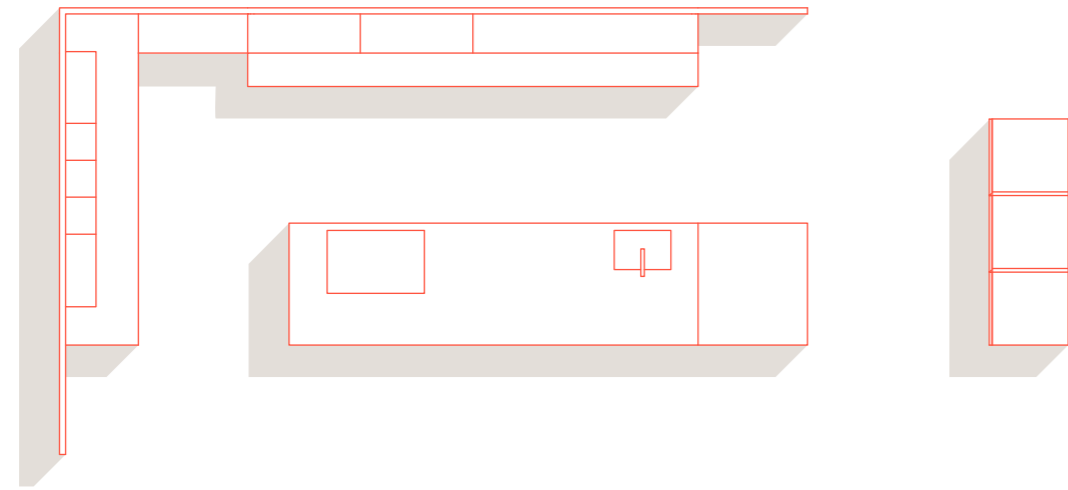

Vetro acidato Steppa

Vetro acidato Vaniglia

Essenza Premium Cenere



Vetro acidato Steppa / Etched Steppa glass



Vetro acidato Vaniglia / Etched Vaniglia glass

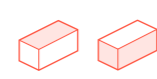

Vetro acidato Steppa, Vetro acidato Vaniglia / Etched Steppa glass, Etched Vaniglia glass

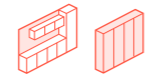

Essenza Premium Cenere / Essenza Premium Cenere veneer





<sup>17</sup> Geometrie sovrapposte, contrasti delicati, materiali che si inseguono in un dialogo ritmico e misurato. Una composizione dall'eleganza discreta, in cui pieni e vuoti si equilibrano con precisione. La cucina si fa spazio abitato, gesto ordinato e profondo, capace di accogliere e trasformare.

<sup>18</sup> Overlapping geometries, subtle contrasts, materials that engage in a rhythmic, measured dialogue. A composition of understated elegance, where solids and voids are perfectly balanced. The kitchen becomes a lived-in space, an intentional, layered gesture that welcomes transformation.



# Declinazioni

La forza della composizione si concentra, trovando un nuovo equilibrio in una dimensione più essenziale. Attraverso combinazioni di materiali e finiture differenti, il progetto assume ogni volta un carattere nuovo. Superfici, tonalità e texture dialogano tra loro dando vita a composizioni capaci di esprimere atmosfere sempre nuove.



EN The strength of the layout is concentrated, finding a new balance in a more minimalist dimension. Through combinations of different materials and finishes, the project takes on a new character every time. Surfaces, shades, and textures communicate with each other, giving life to arrangements capable of expressing ever-new atmospheres.



<sup>17</sup> L'isola si articola in due livelli sovrapposti: la fascia superiore, con ante e top in vetro acidato Steppa, sostenuta da un gambone centrale in Essenza Premium Cenere e quella inferiore, in vetro acidato Vaniglia. Le colonne in Essenza Premium Cenere, con ante sagomate, integrano vani attrezzati per forno e lavastoviglie.



<sup>18</sup> The island is composed of two overlapping levels: the upper section, with doors and worktop in etched Steppa Glass, supported by a central leg in Essenza Premium Cenere; the lower section in etched Vaniglia Glass. The tall units in Essenza Premium Cenere, featuring sculpted doors, incorporate built-in compartments for the oven and dishwasher.



<sup>IT</sup> L'isola si articola in due livelli sovrapposti: la fascia superiore, con ante e top in Laminam Cardoso Nero fiammato, sostenuta da un gambone centrale in Laccato Ossidato Nuvolato Platino e quella inferiore, in Essenza Premium Ossidiana. Le colonne in Laccato Ossidato Nuvolato Platino, con ante sagomate, integrano vani attrezzati per forno e lavastoviglie.

<sup>EN</sup> The island is composed of two overlapping levels: the upper section, with doors and worktop in Laminam Cardoso Nero fiammato ceramic, supported by a central leg in Nuvolato Platino Oxidized Lacquer; the lower section in Essenza Premium Ossidiana. The tall units in Nuvolato Platino Oxidized Lacquer, featuring sculpted doors, incorporate built-in compartments for the oven and dishwasher.



<sup>IT</sup> L'isola a doppio livello caratterizzata dalle ante in Metallo Bronzo e top in Laminam Terra di Pompei fiammato, sostenuta da un gambone centrale in Laccato opaco Terranova, si armonizza con le colonne in Vetro acidato Terranova, con ante sagomate e gole nere.

<sup>EN</sup> Doublelevel island, defined by Bronzo Metal doors and Laminam Terra di Pompei ceramic worktop, supported by a central leg in Matt Terranova Lacquer. The tall units in etched Terranova Glass, featuring sculpted doors, incorporate built-in compartments for the oven and dishwasher.

# ME Slim

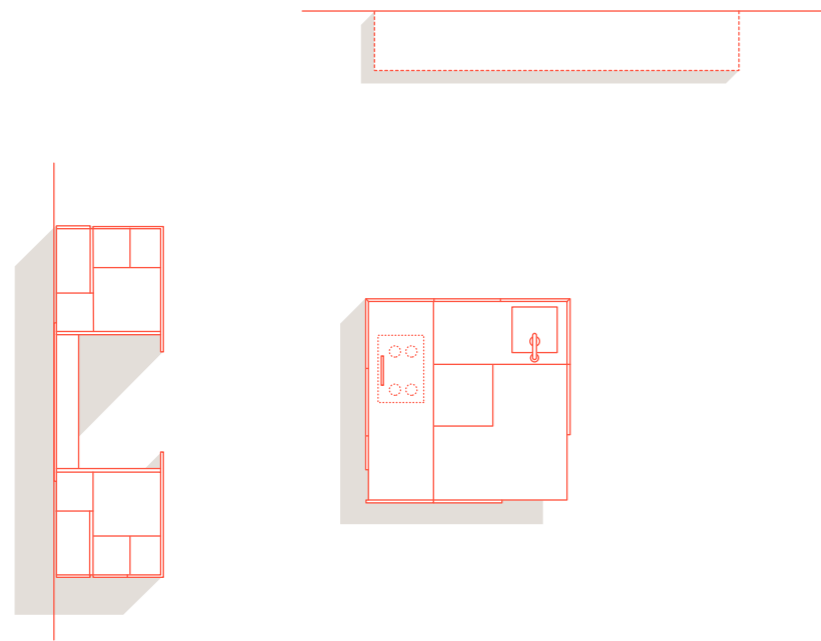

Essenza  
Fresata  
Ambra



Laminam  
Bianco  
Assoluto



Laccato  
Ossidato  
Cacao



Essenza  
Premium  
Ambra



Essenza Fresata Ambra /  
Ambra Milled Veneer



Laminam  
Bianco Assoluto



Laccato Ossidato Cacao /  
Cacao Oxidized Lacquer



Essenza Premium Ambra /  
Ambra Premium Veneer





IT Una combinazione di forme, volumi e toni rappresentativa del carattere della collezione Slim. Un'immagine che vuole trasmettere la freschezza e la leggerezza di un nuovo vocabolario progettuale.

EN A combination of shapes, volumes and tones that defines the character of the Slim collection. An image that seeks to convey the freshness and lightness of a new vocabulary.



# ME Slim

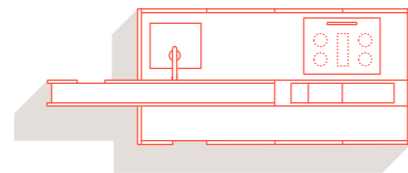
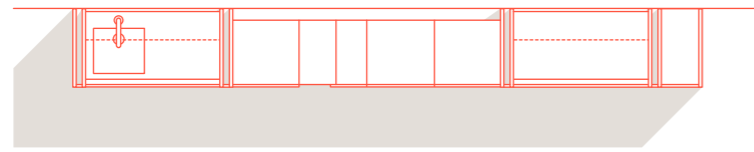

Laccato  
Ossidato  
Lava

Laminam  
In-side  
Cardoso  
Nero  
Fiammato

Laccato  
Opaco  
Efeso FX

Fenix  
Grigio  
Bromo



Laccato Ossidato Lava /  
Lava Oxidized Lacquer

Laminam In-side Cardoso  
Nero Fiammato

Laccato Opaco Efeso FX /  
Efeso FX Matt Lacquer

Fenix Grigio Bromo





<sup>IT</sup> Una casa dal carattere deciso, una composizione in cui le colonne a tutta altezza si fondono nello spazio come una quinta e l'isola scultorea, dai volumi sospesi, dona all'insieme un tratto scenografico.

<sup>EN</sup> A strong-charactered home, a composition in which the full-height tall units blend into the space like a backdrop and the sculptural island, with its suspended volumes, gives the space a scenic feel.





# ME Trim

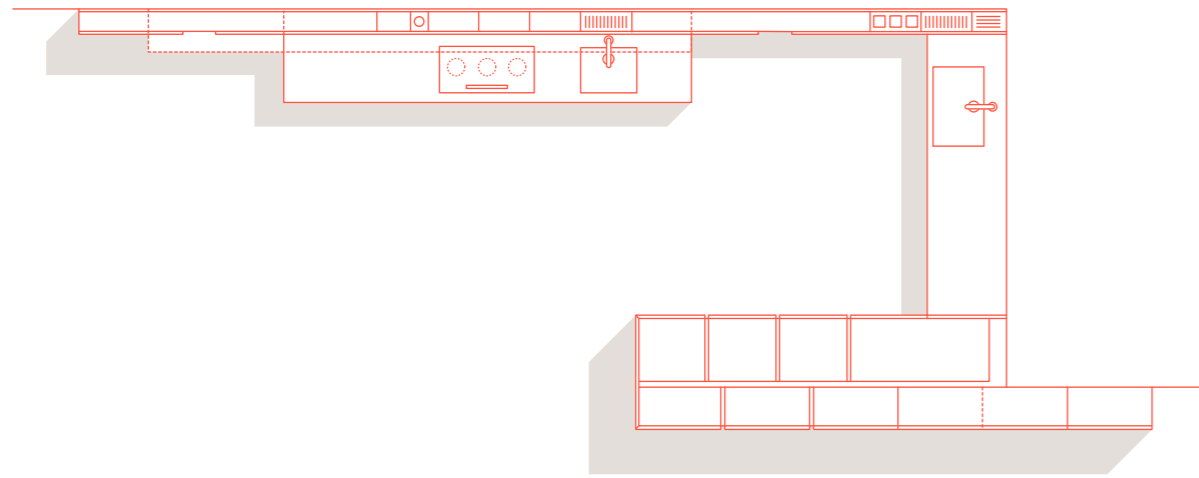

Acciaio Ax Vintage /  
Laccato Opaco Ardesia /  
Essenza Premium Ossidiana /  
Fenix Grigio Stromboli

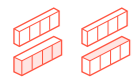

Acciaio Ax Vintage /  
Ax Vintage Steel

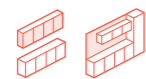

Laccato Opaco Ardesia /  
Ardesia Matt Lacquer



Essenza Premium Ossidiana /  
Ossidiana Premium Veneer



Essenza Premium Ossidiana /  
Ossidiana Premium Veneer



Fenix Grigio Stromboli





IT Trim coniuga l'essenzialità e la leggerezza della nuova anta con struttura in alluminio con l'eleganza formale e l'effetto di sospensione tipico dell'apertura con gola. Il risultato è un sistema versatile, declinabile all'infinito.

EN Trim meets the essentiality and lightness of the new aluminum-honeycomb door with the formal elegance and suspension, typical of an opening with a handle-rail. The result is a versatile system that can be infinitely declined.



# ME Trim

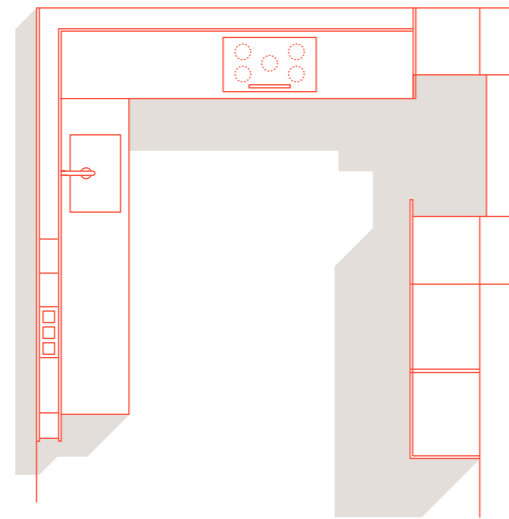

Laccato Opaco Artico



Laminam In-side Piasentina Grigia Fiammata



Fenix Bianco Kos



Essenza Premium Cenere



Laccato Opaco Artico / Artico Matt Lacquer



Laminam In-side Piasentina Grigia Fiammata



Fenix Bianco Kos



Essenza Premium Cenere / Cenere Premium Veneer





<sup>17</sup> Una casa pensata per una famiglia, una cucina dalle dimensioni generose che si apre alla zona living pur mantenendo la propria identità grazie al Muretto attrezzato a due altezze che circostrive e filtra la zona operativa.

<sup>EN</sup> A home designed around the family, a wider-sized kitchen spreads onto the living area while maintaining its own identity thanks to the double-height Muretto upright that delineates and filters the work area.



# M2: Riga Petra Goccia Linea Crea

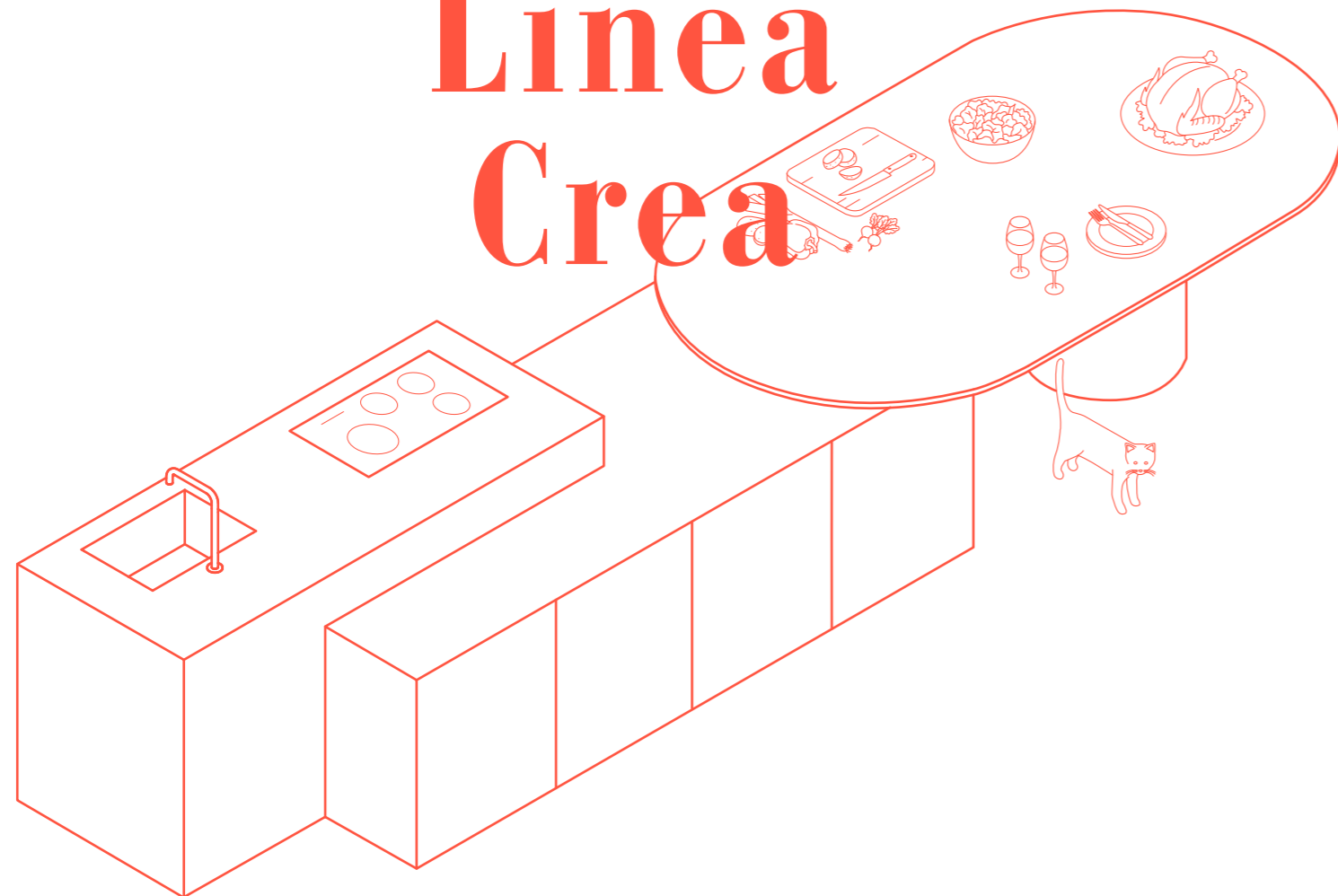

**Riga**

p.76

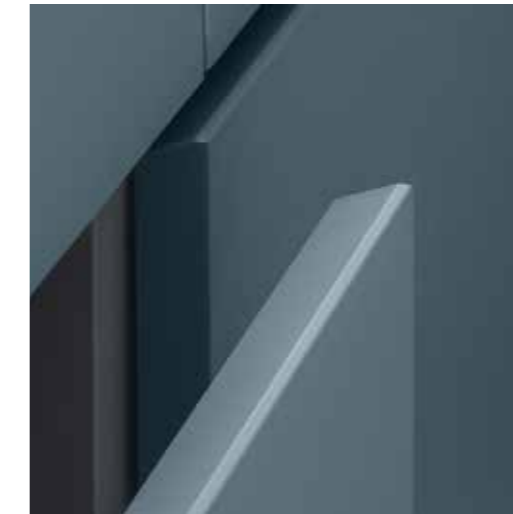
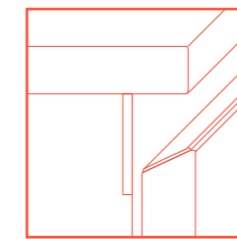

**Petra**

p.98

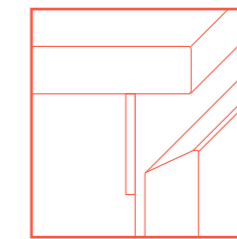

**Goccia**

p.110

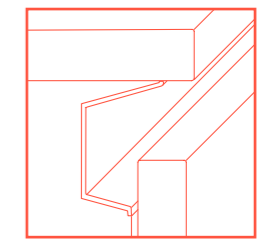

**Linea**

p.116

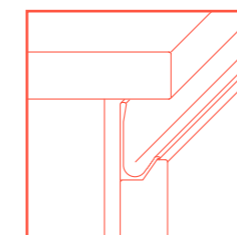

**Crea**

p.134

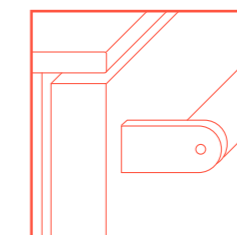

# M2 Riga

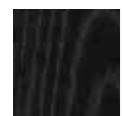
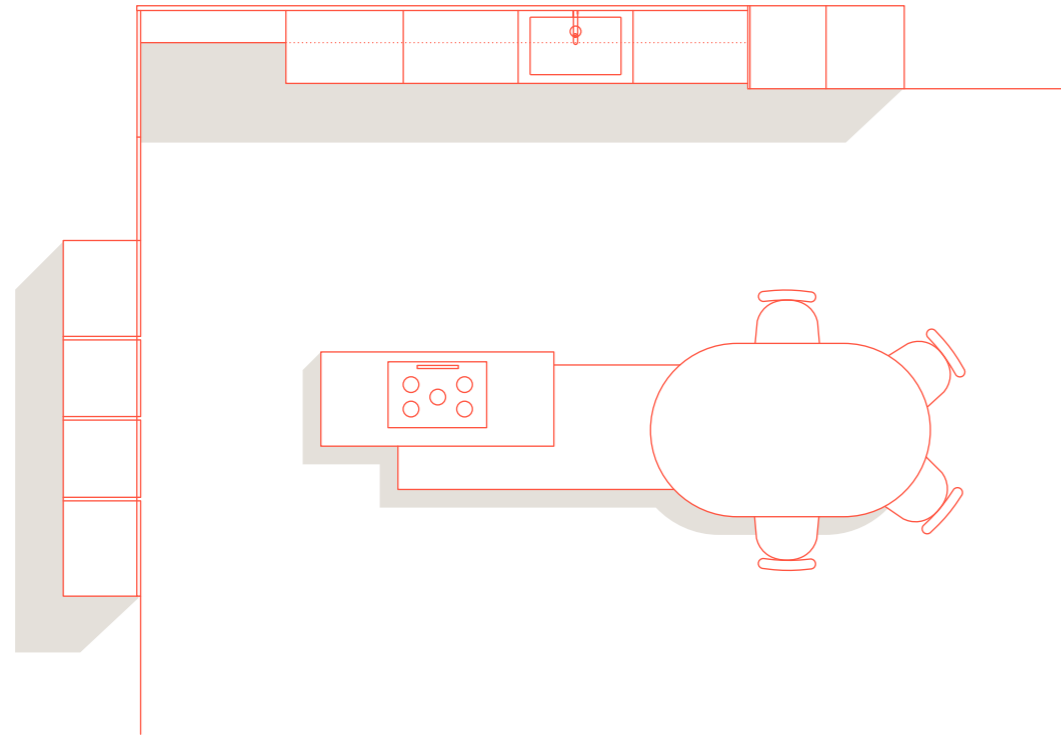

Materico  
Extra  
Quercia  
Nero



Laminato  
Smart  
Dune  
Marsiglia



Fenix  
Grigio  
Stromboli



Materico Extra Nero / Quercia Nero Extra  
Textured melamine

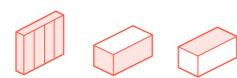

Laminato Smart Dune Marsiglia / Dune  
Marsiglia Smart Laminate



Fenix Grigio Stromboli

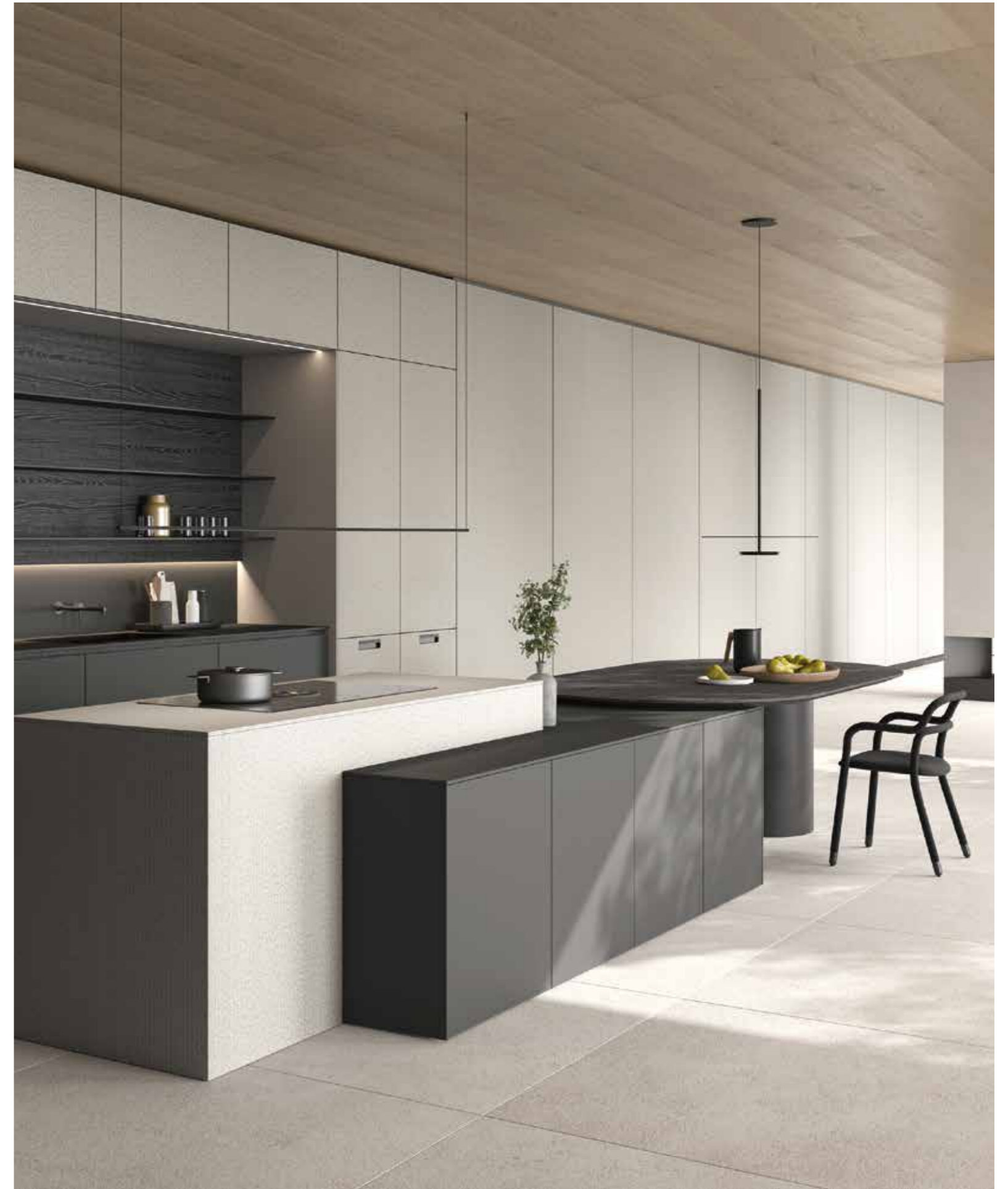



<sup>17</sup> Una composizione che diventa parte dell'architettura d'interni, nel segno di un piacevole minimalismo. Protagonista è l'isola composta da un insieme di volumi che accolgono diverse funzioni: preparazione, contenimento, convivialità.

<sup>18</sup> An arrangement that becomes one with the interior architecture in a spirit that's all about minimalism. The star of the kitchen is the island, composed of a set of volumes that bring together various functions: food preparation, storage, conviviality.





# M2 Riga G

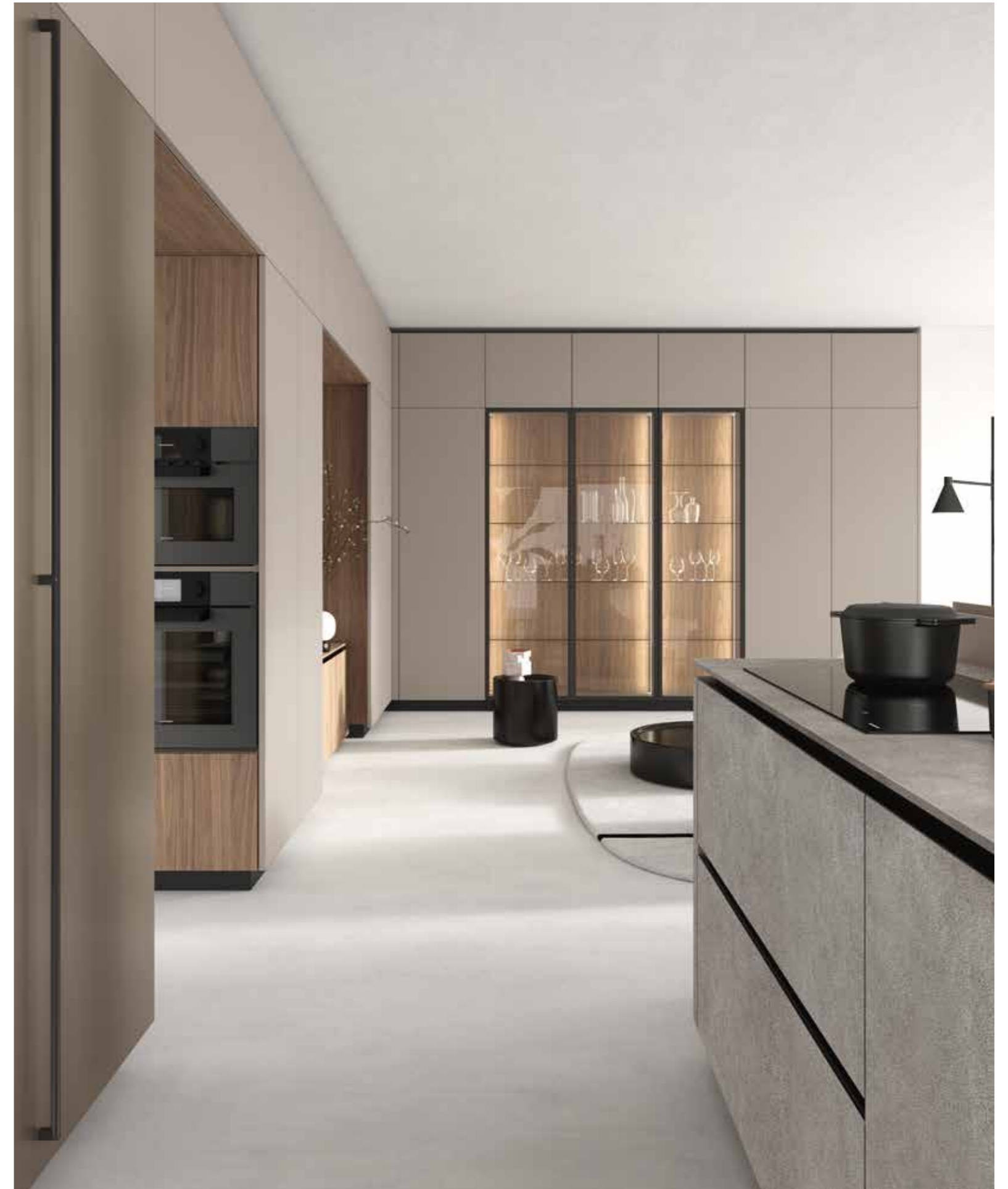
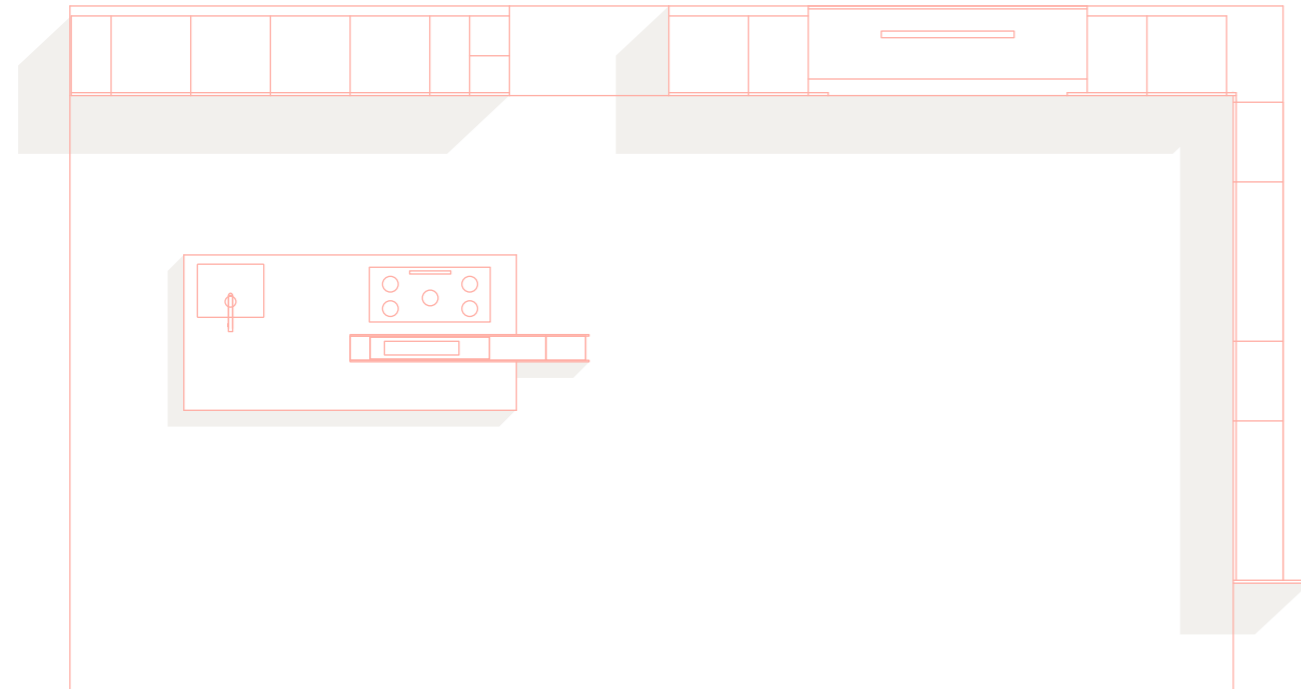



<sup>17</sup> Cucina e living si fondono in un unico spazio accogliente e ricercato. Una sensazione di continuità accentuata dalla linearità estetica della composizione, senza elementi tecnici direttamente in vista e con maniglie che diventano quasi dei segni grafici.

<sup>18</sup> The kitchen and the living room blend in a single, inviting and refined space. A sense of seamless continuity is enhanced by the aesthetic linearity of the arrangement that conceals all its technical elements and features handles that create an almost graphic pattern.





# M2 Riga M

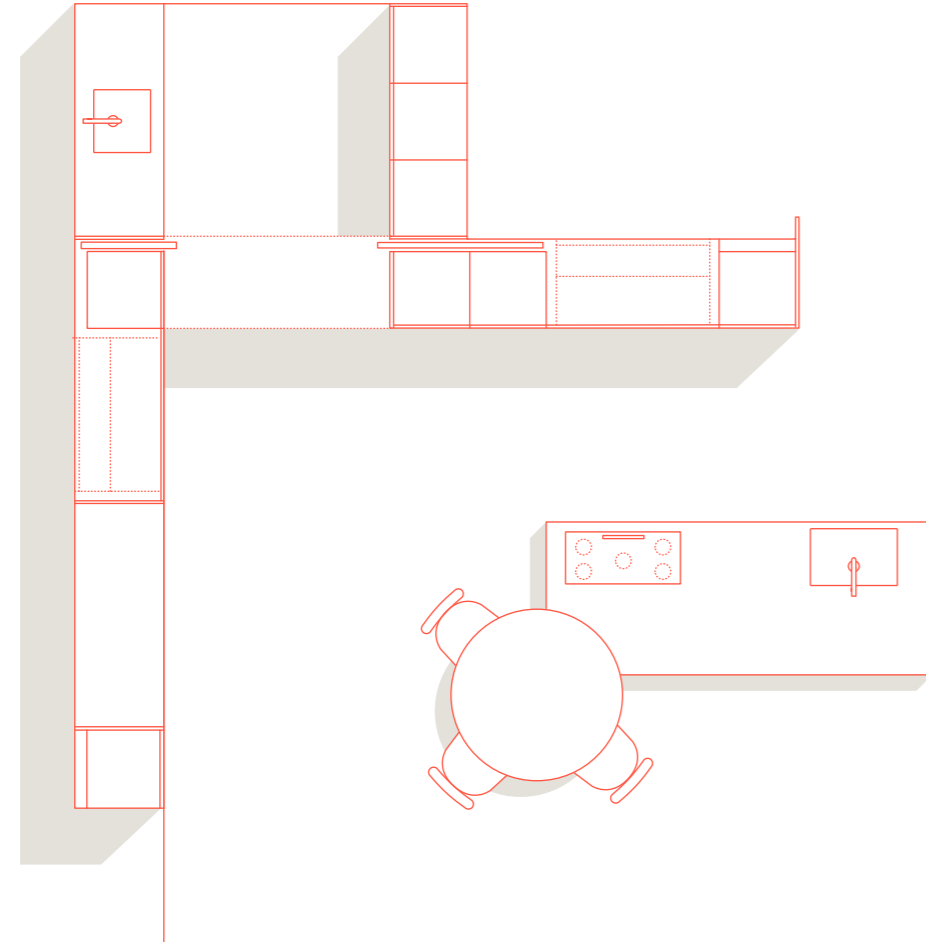

Laccato  
Opaco  
Magnolia

Essenza  
Silva  
Miele

Laminato  
Piasentina



Laccato Opaco Magnolia /  
Magnolia Matt Lacquer

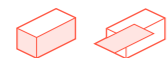

Essenza Silva Miele /  
Silva Miele Veneer



Laminato Piasentina /  
Piasentina Laminate







Il legno, con il suo naturale calore, caratterizza questo ambiente cucina creando una sensazione rassicurante, in equilibrio fra la tradizione e la contemporaneità.

With its natural warmth, wood distinguishes this kitchen and creates a reassuring feeling poised between traditional and contemporary beauty.

# M2 Petra

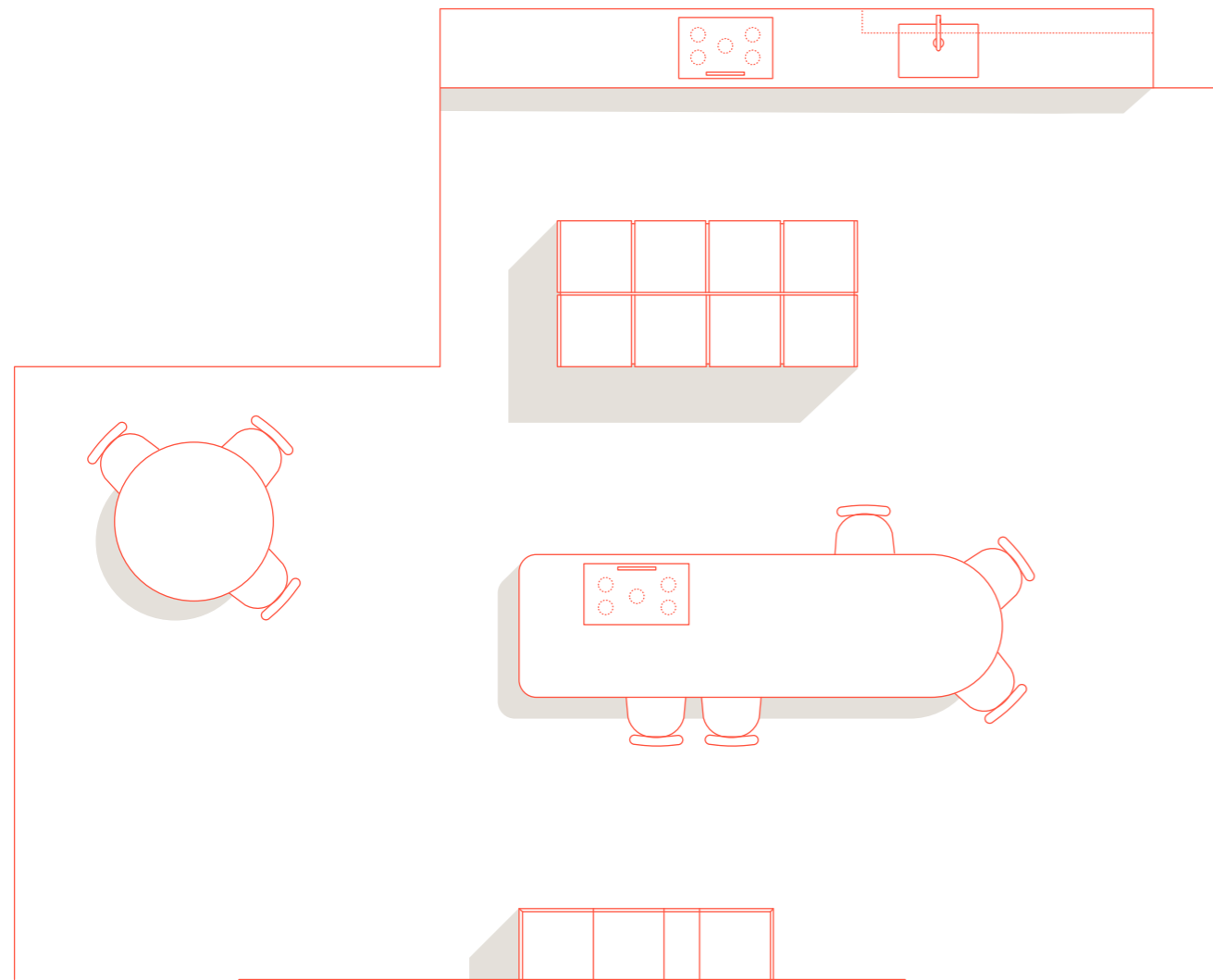

Laccato  
Opaco  
Rosso  
Namib FX



Agglomerato  
Marmo  
Palazzo  
Foscari



Materico  
Extra  
Cortecchia  
Biondo



Laccato  
Opaco  
Giallo  
Evora FX



Laccato Opaco Rosso Namib  
FX / Rosso Namib FX Matt  
Lacquer



Agglomerato Marmo Palazzo  
Foscari / Palazzo Foscari  
Composite Marble



Materico Extra Cortecchia  
Biondo / Cortecchia Biondo  
Extra Textured melamine



Laccato Opaco Giallo  
Evora FX / Giallo Evora  
FX Matt Lacquer





“ La forza del colore è la chiave espressiva di un ambiente cucina da vivere liberamente e senza pensieri. Un open space ampio e luminoso che invita alla convivialità.

“ The energy of colour is the expressive medium of a kitchen designed to be used in a carefree, boundless way. A large and luminous open space beckons you to enjoy togetherness.

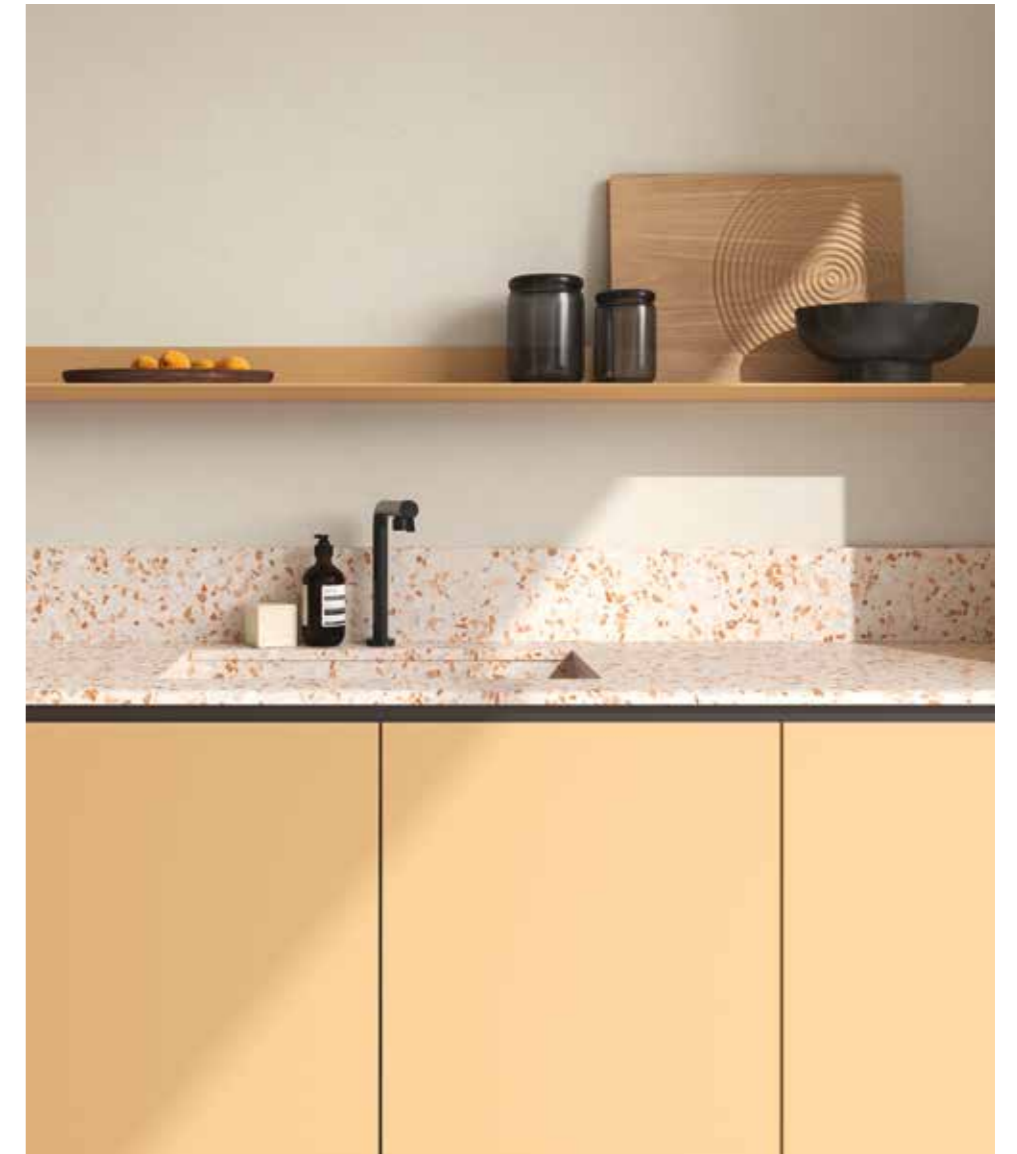

# M2 Petra M

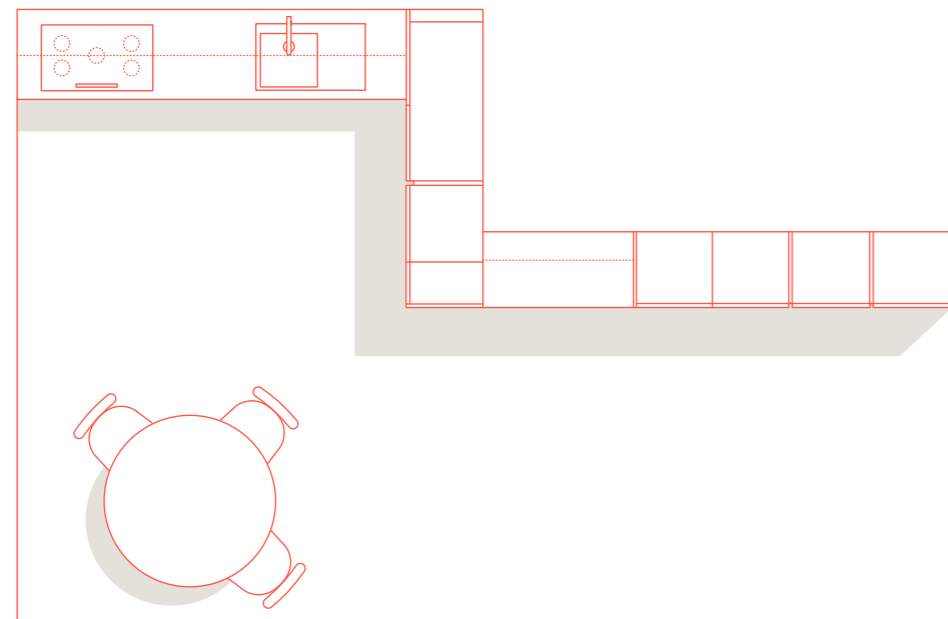

Materico Extra Mica Ferro



Fenix Blu Shaba



Anta Quadra vetro fumè



Agglomerato Marmo Palazzo Maffei



Materico Extra Mica Ferro / Mica Ferro Extra Textured melamine



Fenix Blu Shaba



Vetro fumè / Smoked glass



Agglomerato Marmo Palazzo Maffei / Palazzo Maffei Composite Marble





17 Una cucina contemporanea ambientata in una casa d'epoca, genera un dialogo che diventa armonia. L'orizzontalità delle basi è enfatizzata dalla gola che si estende per l'intera larghezza.

18 A contemporary kitchen installed in a period building generates a harmonious dialogue. A horizontal display of base units is highlighted by the grip channel that runs along its entire width.



# M2 Goccia

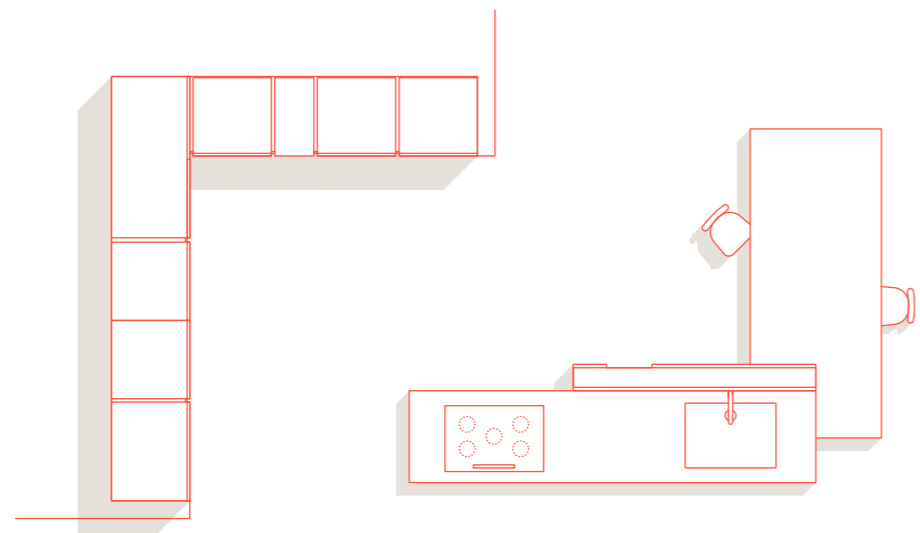

Fenix Verde Comodoro  
 Fenix Nero  
 Laccato Opaco Verde Salvia  
 Rovere Grigio



Fenix Verde Comodoro  
 Fenix Nero  
 Laccato Opaco Verde Salvia / Verde Salvia Matt Lacquer  
 Rovere Grigio / Rovere Grigio Veneer  
 Rovere Grigio / Rovere Grigio Veneer

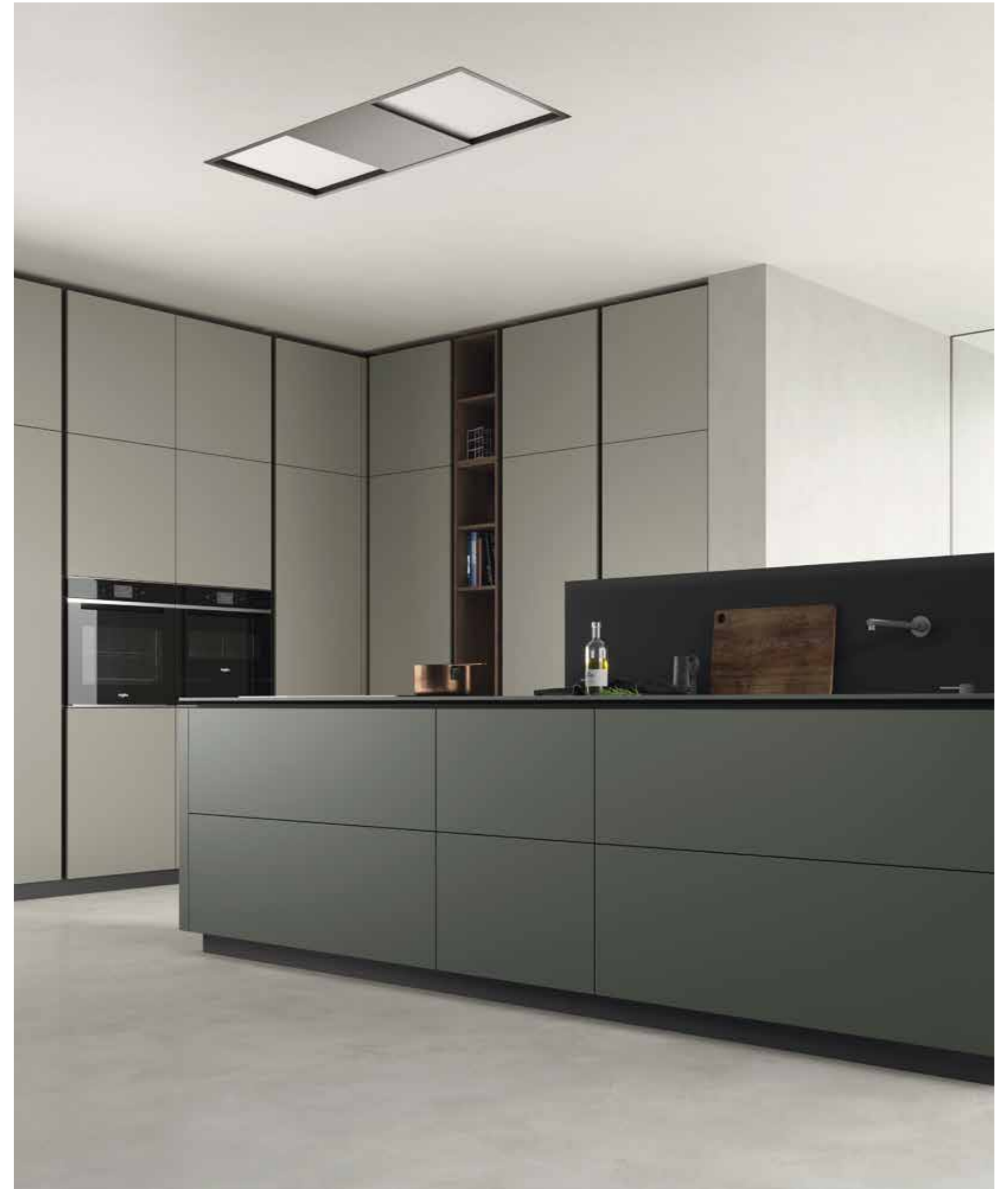



<sup>IT</sup> Goccia interpreta l'ambiente cucina lasciando spazio alla libertà progettuale, per realizzare case capaci di assecondare i nostri bisogni.

<sup>EN</sup> Goccia gives to designers many tools, allowing this range to properly understand the kitchen environment, all with the goal to meet our needs.



# M2 Linea

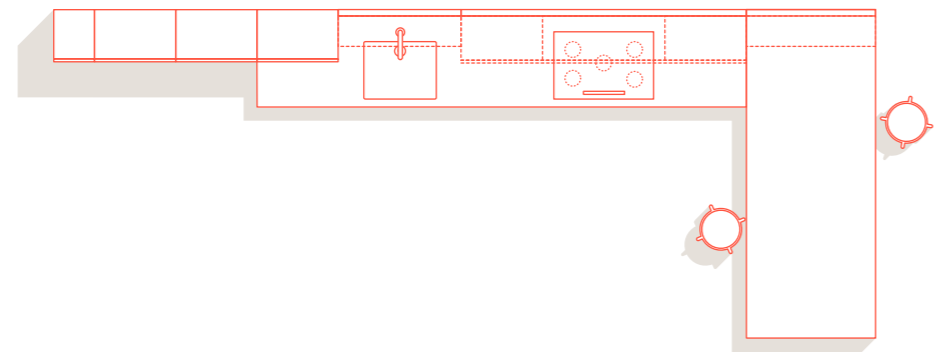

Fenix Grigio

Laccato Opaco Antracite

Materico Extra Mica Ferro

Materico Larice Nero

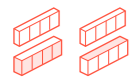

Fenix Grigio



Laccato Opaco Antracite / Antracite Matt Lacquer



Laccato Opaco Antracite / Antracite Matt Lacquer



Materico Extra Mica Ferro / Mica Ferro Extra Textured-melamine



Materico Larice Nero / Larice Nero Textured-melamine





<sup>17</sup> Un locale industriale trasformato in appartamento e una cucina nella quale i toni di grigio delle ante si accostano sapientemente al nero dei profili.

<sup>EM</sup> An industrial space transformed into an apartment and a kitchen in which the unit doors in shades of grey are skilfully combined with the black of the profiles.



# M2 Linea

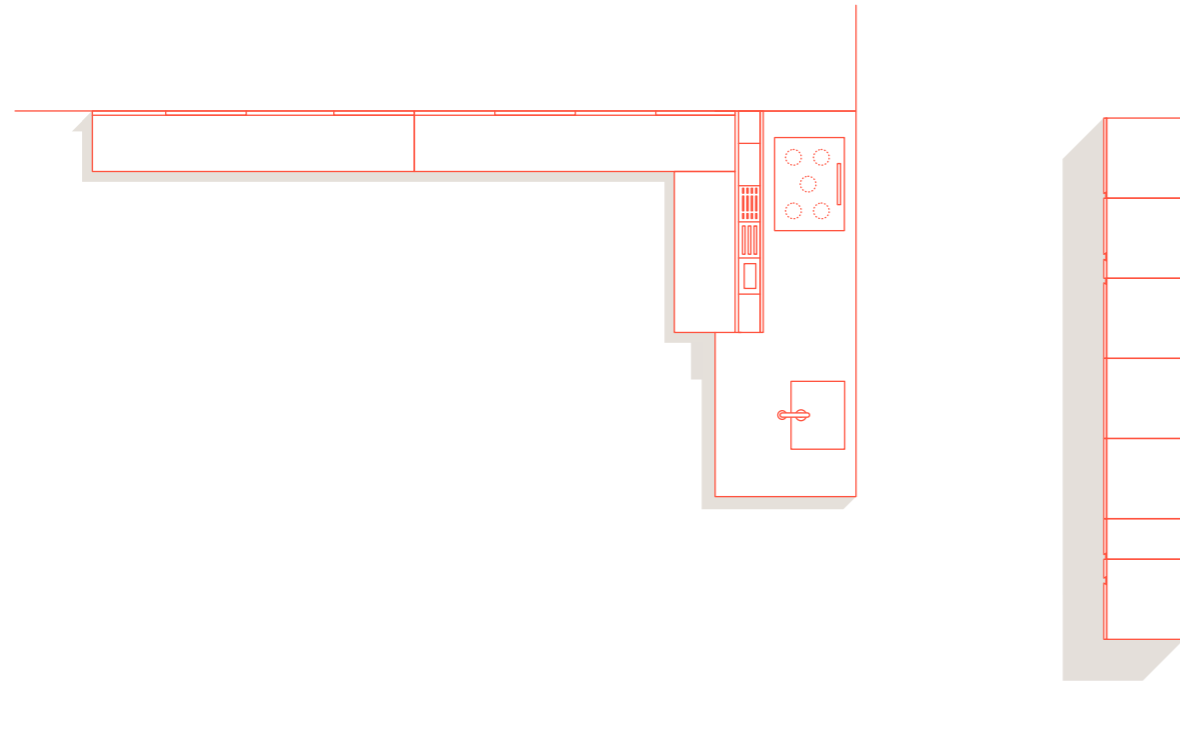

Laminato  
Omnia  
Kandia  
Bianco

Fenix  
Grigio  
Efeso

Fenix  
Bianco  
Kos

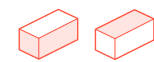

Laminato Omnia Kandia  
Bianco / Kandia Bianco  
Omnia Laminato



Fenix Grigio Efeso



Fenix Bianco Kos





<sup>IT</sup> Trasferiscono una sensazione di benessere le texture naturali di questo spazio cucina, progettato per la convivialità e completo di tutte le moderne funzionalità operative.

<sup>EN</sup> A sense of well-being is conveyed by the natural textures of this kitchen space, designed for socialising and fitted with all the modern conveniences.



# M2 Linea

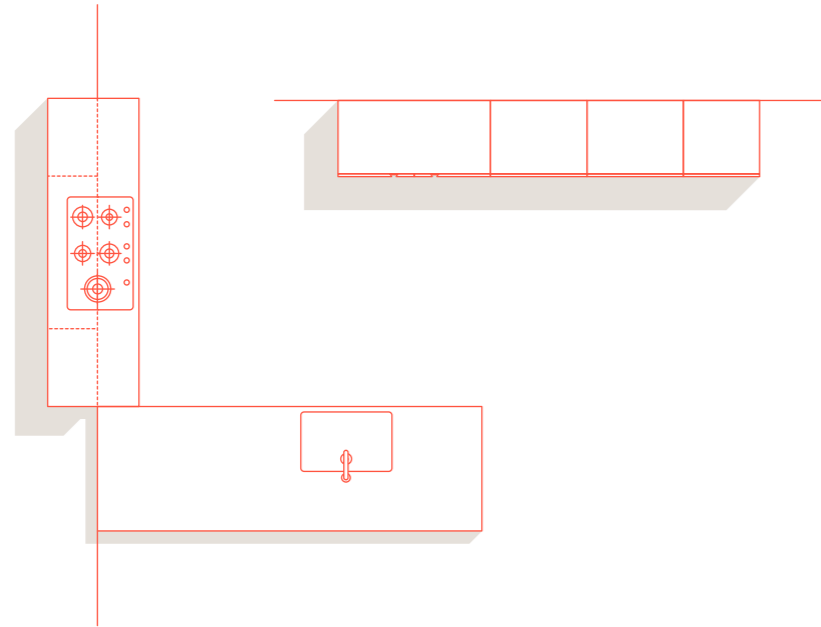

Fenix Beige Colostrai



Laminato Piasentina



Materico Extra Eucalipto Tabacco



Fenix Beige Colostrai



Fenix Beige Colostrai



Laminato Piasentina / Piasentina Laminare



Materico Extra Eucalipto Tabacco / Eucalipto Tabacco Extra Textured-melamine

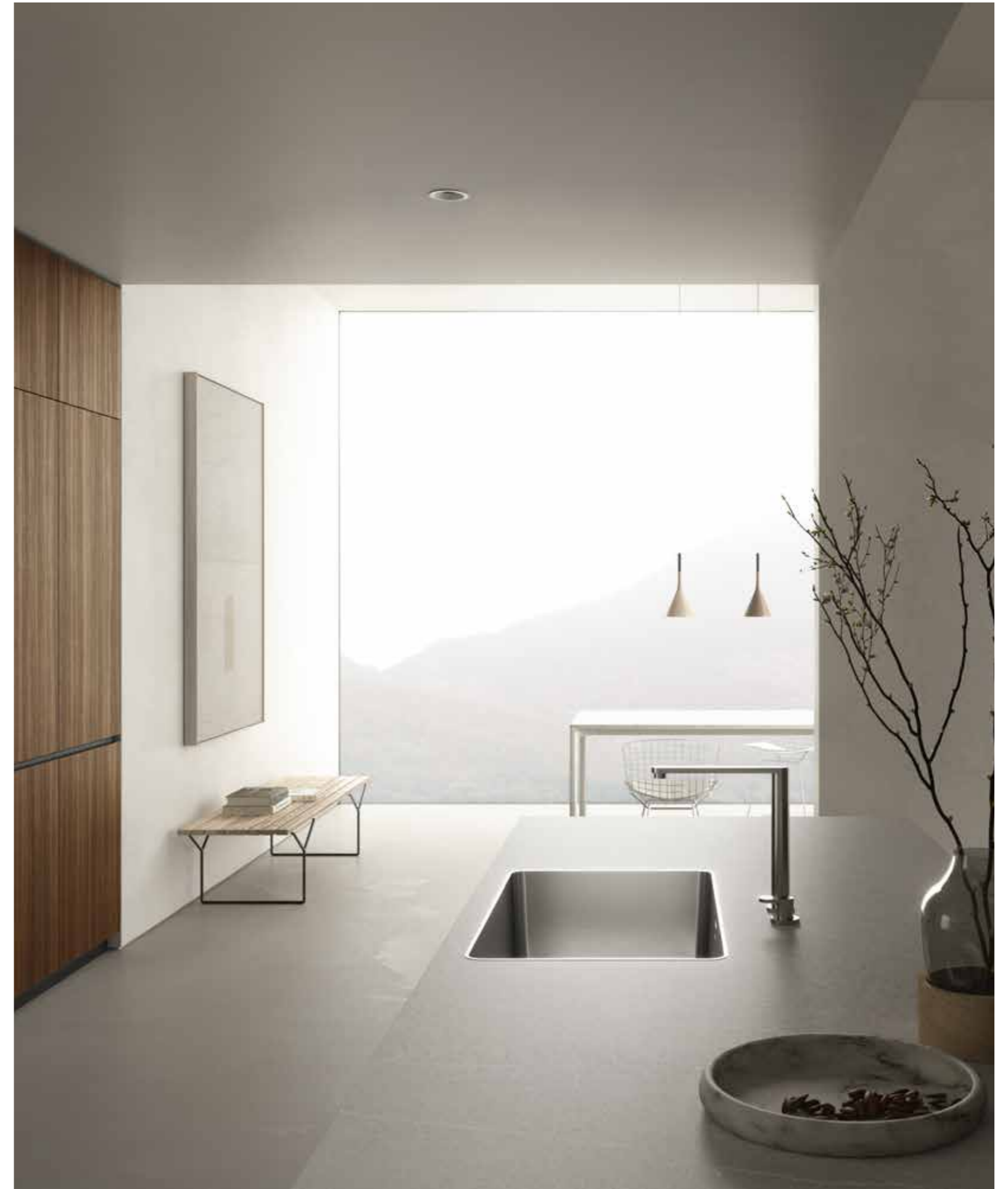



<sup>17</sup> Ispirazioni scandinave per una cucina nella quale si coglie con immediatezza l'estrema pulizia delle linee e caratterizzata dall'inconfondibile design del profilo di apertura di Linea.

<sup>EN</sup> Scandinavian inspirations for a kitchen in which the extreme cleanliness of the lines is immediately apparent and which is characterized by the unmistakable design of the Linea opening profile.



# M2 Crea

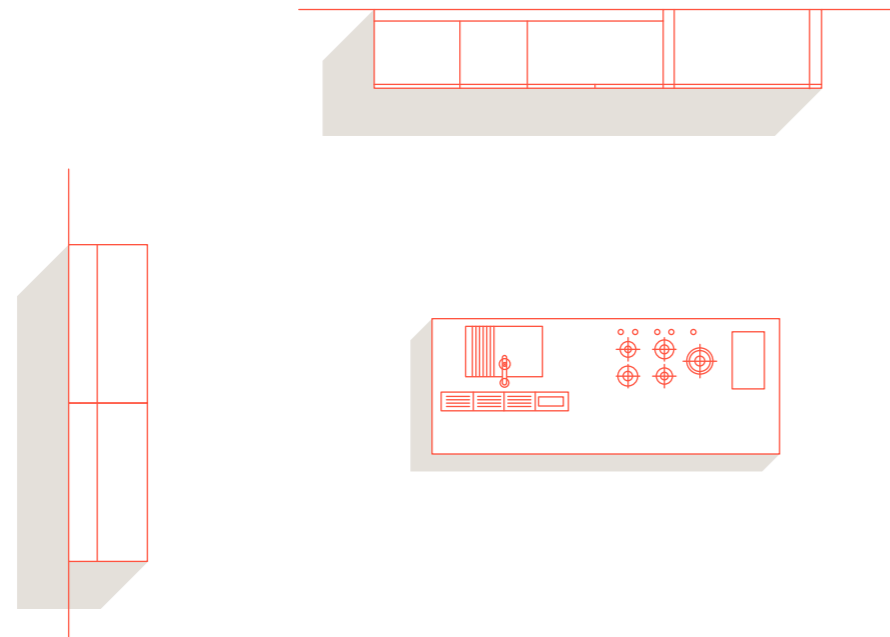

Fenix Nero    Acciaio Satinato    Essenza Silva Pece    Laccato Opaco Nero



Fenix Nero    Acciaio Satinato / Satin Steel    Essenza Silva Pece / Silva Pece Veneer    Laccato Opaco Nero / Nero Matt Lacquer





<sup>IT</sup> Le maniglie Max, la leggerezza della cappa sospesa e la completezza di dotazioni tecnologiche in una cucina del sistema M2 che invita a condividere il piacere della buona tavola.

<sup>EN</sup> The Max handles, the lightness of the suspended hood and comprehensive technological fittings in an M2 kitchen system is an invitation to share in the pleasure of good food.



**Dati  
tecnici  
/  
Technical  
data**

**I sistemi Meson's  
/  
Meson's Systems**

p. 142

**ME**  
p. 144

**M2**  
p. 146

**Materiali e finiture  
/  
Materials and finishes**

p. 150

# MESON'S

ME

## Materia Pura

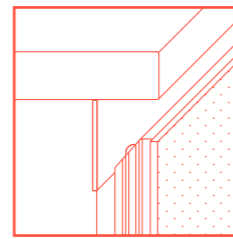

**IT** Anta con telaio in alluminio sagomato che accoglie e protegge un pannello estetico in materiale prezioso. Declinabile in due configurazioni: Materia Pura, con gola piatta e Materia Pura G, con gola a incavo per migliorare la prensilità.

**EN** A door with a shaped aluminium frame that houses and protects an aesthetic panel in precious material. Available in two configurations: Materia Pura, with a flat grip recess, and Materia Pura G, with an Incavo grip recess for enhanced ergonomics.

## Slim

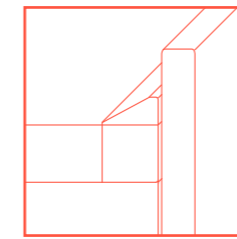

**IT** Anta essenziale, sp.12mm con struttura in alveolare di alluminio, che si estende oltre l'altezza del piano di lavoro a definire la presa d'apertura, abbinata a un top sagomato ad invaso.

**EN** A minimalist 12mm thick door with an aluminium honeycomb structure which extends beyond the height of the worktop to define the groove handle, combined with a recessed-edge top.

## Trim

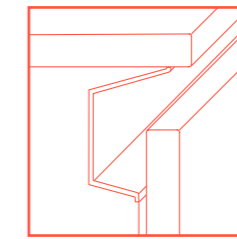

**IT** Il modello coniuga l'essenzialità e la leggerezza dell'anta con struttura in alluminio da 12 millimetri con la praticità e l'eleganza formale della sospensione tra struttura delle basi e top tipiche dell'apertura con gola a incavo.

**EN** The model combines the minimalism and lightness of the 12 mm aluminium-structured door with the practicality and formal elegance of the gap between the base unit structure and the top, typical of the Incavo grip recess.

M2

## Riga

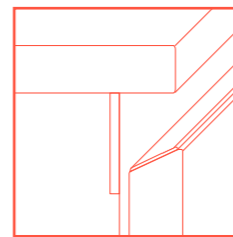

**IT** Una minimale trafila in alluminio protegge la parte prensile dell'anta smussata a 30°, con una leggera zigrinatura che ne migliora la presa. Declinabile in tre configurazioni: Riga, con gola piatta; Riga G, con gola a incavo per migliorare la prensilità, Riga M per un effetto monolitico.

**EN** A minimal extruded aluminium profile that protects the grip edge of the 30° bevelled door and features a slightly knurled surface that improves its ergonomics. Available in three configurations: Riga, with a flat grip recess; Riga G, with an Incavo grip recess for improved ergonomics, Riga M for a monolithic effect.

## Petra

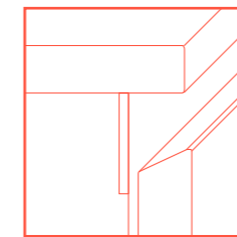

**IT** Modello dall'anta con sezione smussata a 30° nella parte prensile per minimizzare lo spessore percepito. Declinabile in tre configurazioni: Petra, con gola piatta; Petra G, con gola a incavo per migliorare la prensilità, Petra M per un effetto monolitico.

**EN** Model with a door featuring a 30° bevelled section along the opening edge to minimise its perceived thickness. Available in three configurations: Petra, with a flat grip recess; Petra G, with an Incavo grip recess for enhanced ergonomics, Petra M for a monolithic effect.

## Goccia

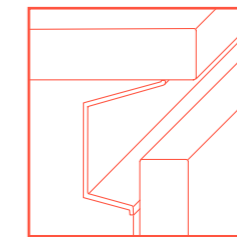

**IT** Caratterizzato dalla presenza del profilo gola sottotop "a incavo", su disegno esclusivo Meson's, che ottimizza la prensilità dell'anta e permette di massimizzare lo stacco tra frontali e top, con un effetto di leggerezza e sospensione.

**EN** Characterised by the presence of the under-top Incavo grip recess, based on an exclusive Meson's design, which optimises door opening ergonomics and allows for a maximised gap between fronts and worktops, creating a floating effect and fostering visual lightness.

## Linea

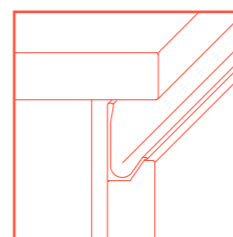

**IT** Il particolare che contraddistingue il modello è il design del profilo di apertura: una trafila in alluminio sagomata integrata all'anta che ne determina l'elemento prensile in infinite combinazioni grafiche.

**EN** The distinctive trait of the model is the design of its opening profile: a shaped aluminium extrusion integrated into the door that determines the gripping element in endless graphic combinations.

## Crea

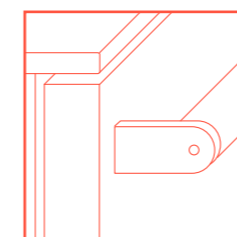

**IT** Caratterizzato dalla presenza della maniglia, un modello che privilegia la praticità d'utilizzo, aggiungendo allo stesso tempo un segno distintivo al progetto a seconda della maniglia scelta.

**EN** Characterised by the presence of the handle, this model prioritises practical use while adding a distinctive mark to the project depending on the chosen handle

## Memo

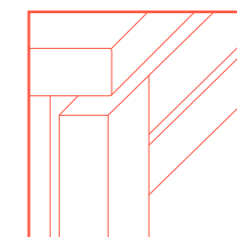

**IT** Un'anta a telaio in legno che accoglie e integra, nel massello superiore opportunamente lavorato, un profilo in alluminio che sottolinea il punto di presa e diventa un raffinato segno estetico e funzionale.

**EN** A door with a wooden frame that houses and integrates, within the appropriately crafted upper solid wood edge, an aluminium profile that highlights the grip point and becomes a refined aesthetic and functional feature.

## ME Materia Pura

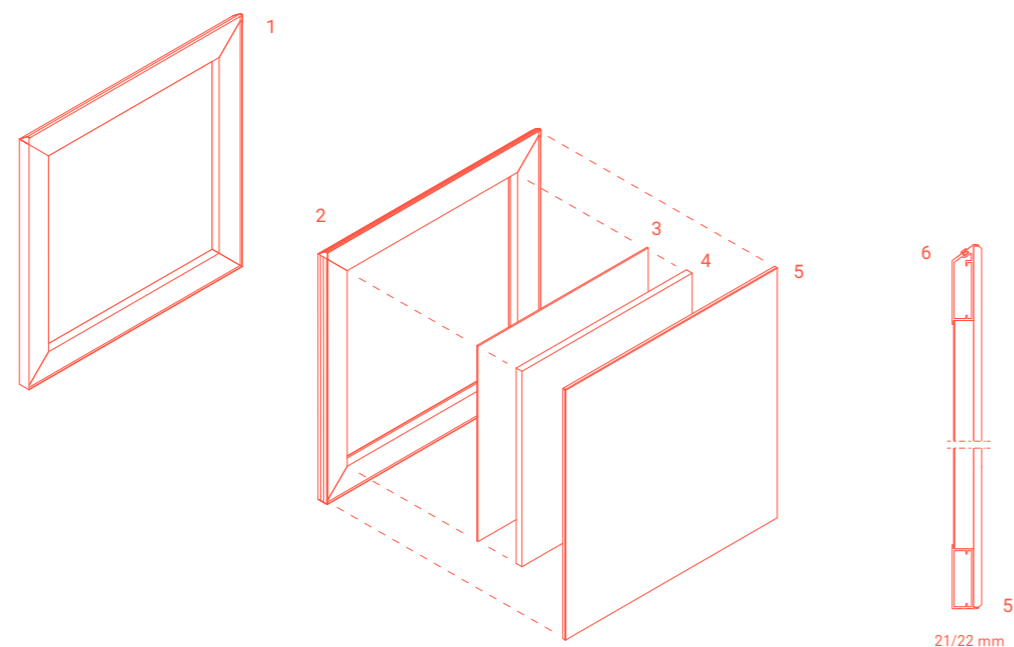

- |   |  |
|---|--|
| 1 Profilo alluminio con sporgenza protettiva / Aluminium profile with protective overhang | 4 Elemento isolante / Insulating core  |
| 2 Profilo alluminio / Aluminium profile   | 5 Pannello decorativo / Decorative front panel                                   |
| 3 Pannello retro in finitura / Back panel with matching finish.                           | 6 Profilo guarnizione per una migliore presa / Gasket profile for improved grip. |

### Gole / Grip recesses

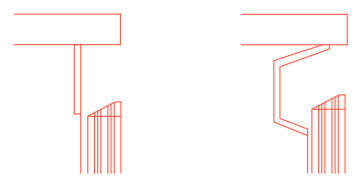

Materia Pura

Materia Pura G

### Posizionamento / Positioning

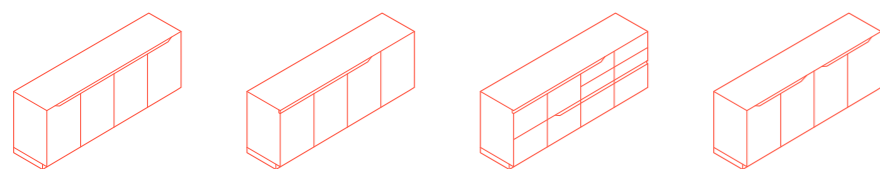

Opzione apertura S / S opening option

### Finiture profilo telaio e gola / Door frame and grip recess finishes

Anodizzato Nero  
/ Nero AnodisedAnodizz. Opale  
/ Opale Anod.

## ME Slim



### Dettaglio anta / Door detail

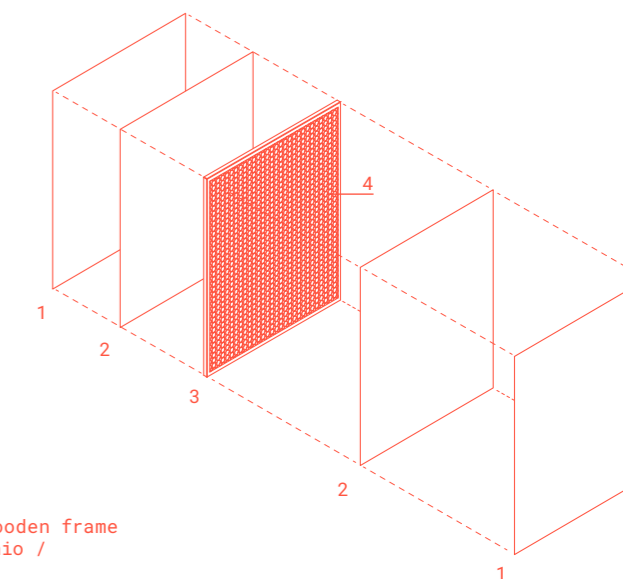
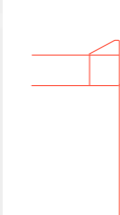

- |  |
|--|
| 1 Finitura / Finish  |
| 2 Foglio in alluminio 10/10 / 10/10 aluminium sheet              |
| 3 Profilo perimetrale in legno / Wooden frame                    |
| 4 Struttura in alveolare di alluminio / Honeycomb aluminium core |

## ME Trim



### Dettaglio anta / Door detail

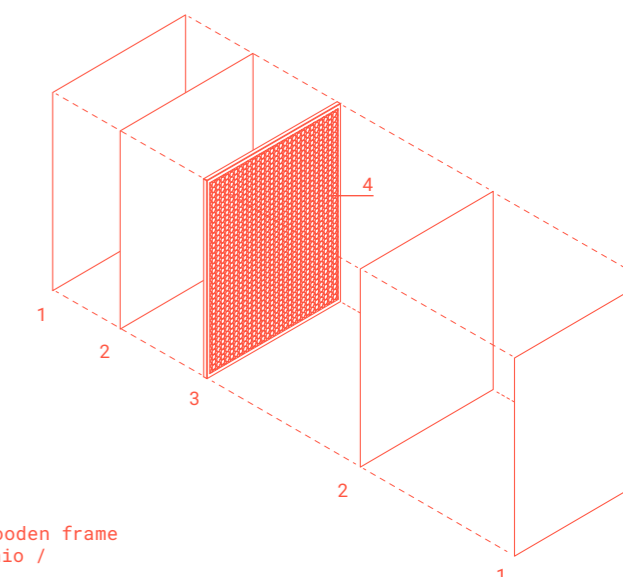

- |  |
|--|
| 1 Finitura / Finish  |
| 2 Foglio in alluminio 10/10 / 10/10 aluminium sheet              |
| 3 Profilo perimetrale in legno / Wooden frame                    |
| 4 Struttura in alveolare di alluminio / Honeycomb aluminium core |

# M2 Riga



Gole / Grip recesses

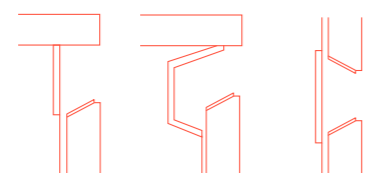

Riga

Riga G

Riga M

Profilo su bordo anta / Door profile



Riga e Riga G

Riga M

Finiture profilo gola / Grip recess finishes

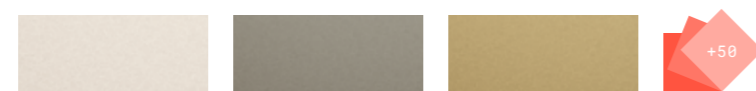

Anodizz. Platino / Platino Anod.

Anodizz. Perla / Perla Anod.

Anodizz.Champagne / Champagne Anod.

Laccati / Lacquers

Finiture profilo anta / Door profile finishes



Anodizz. Platino / Platino Anod.

Anodizz. Perla / Perla Anod.

Anodizz.Champagne / Champagne Anod.

Anodizzato Cacao / Cacao Anodised

Anodizzato Nero / Nero Anodised

Posizionamento / Positioning

# M2 Goccia



Gole / Grip recesses

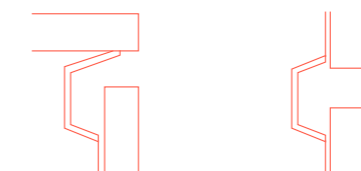

Profilo gola per incavo superiore / Incavo upper grip recess

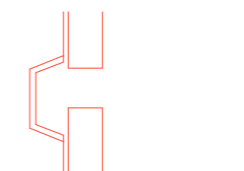

Profilo gola per incavo centrale / Incavo central grip recess

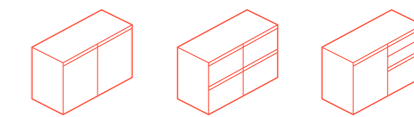

Finiture profilo gola / Grip recess finishes

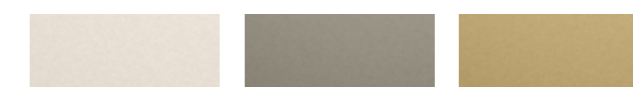

Anodizz. Platino / Platino Anod.

Anodizz. Perla / Perla Anod.

Anodizz.Champagne / Champagne Anod.

# M2 Linea



Gole / Grip recesses

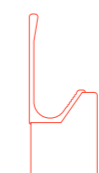
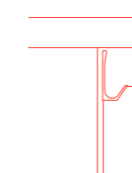

Profilo su bordo anta / Door profile

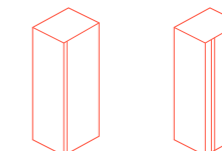

Finiture profilo Linea / Linea profile finishes



Anodizz. Platino / Platino Anod.

Anodizz. Perla / Perla Anod.

Anodizz.Champagne / Champagne Anod.

Anodizzato Cacao / Cacao Anodised

Anodizzato Nero / Nero Anodised



Laccati / Lacquers

# M2 Petra



Gole / Grip recesses

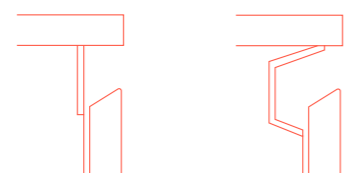

Petra

Petra G

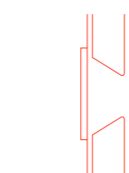

Petra M

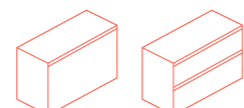

Petra e Petra G

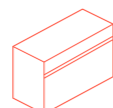

Petra M

Finiture profilo gola / Grip recess finishes

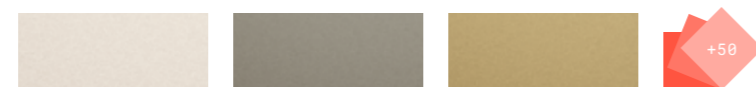

Anodizz. Platino / Platino Anod.

Anodizz. Perla / Perla Anod.

Anodizz.Champagne / Champagne Anod.

Laccati / Lacquers

Posizionamento / Positioning

# M2 Crea



Maniglie / Handles

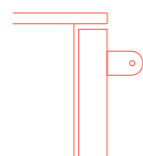

Mini

Posizionamento / Positioning

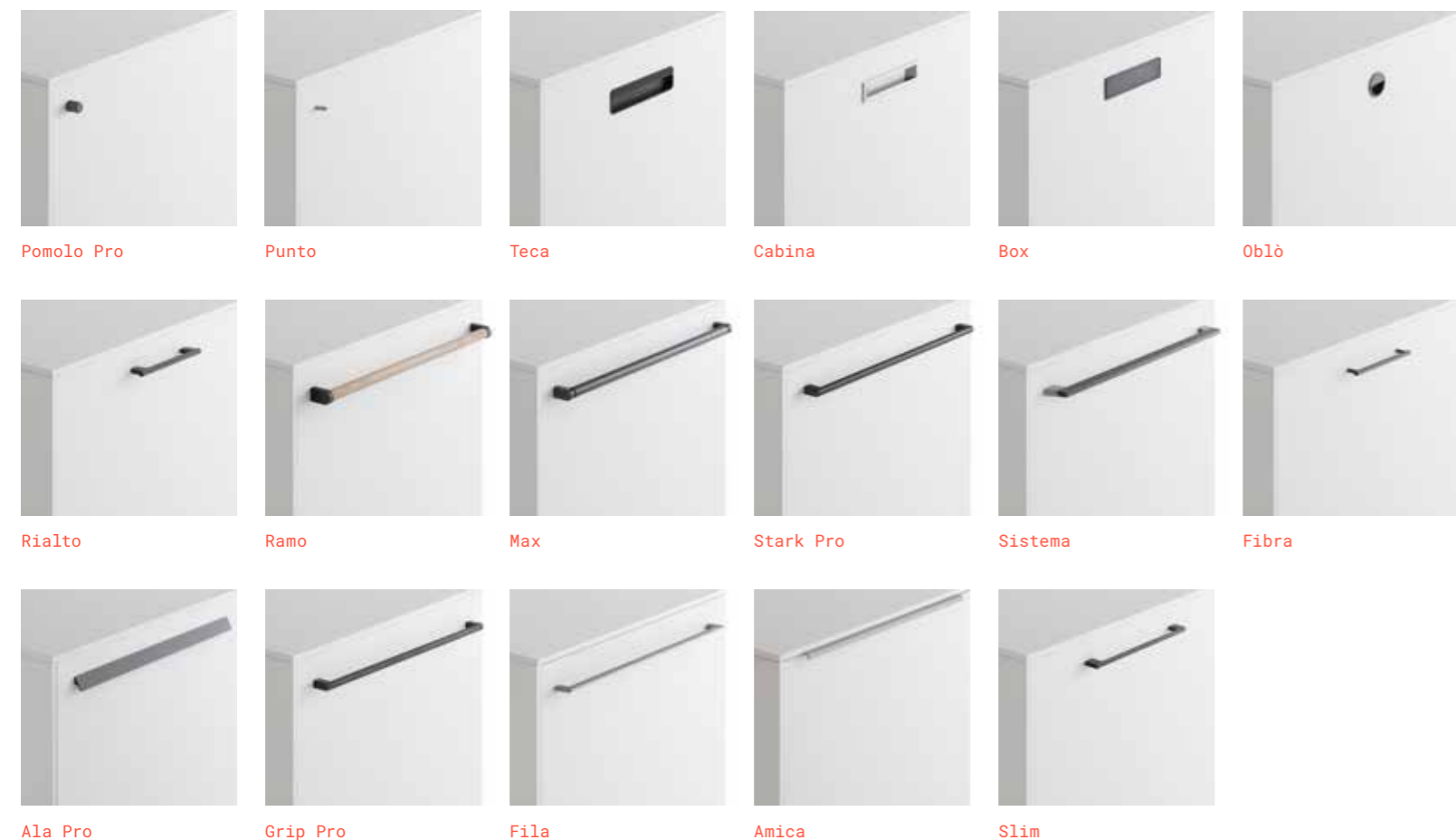

# M2 Memo



Dettaglio anta / Door detail



Posizionamento / Positioning



Finiture anta e profilo / Door and profile finishes

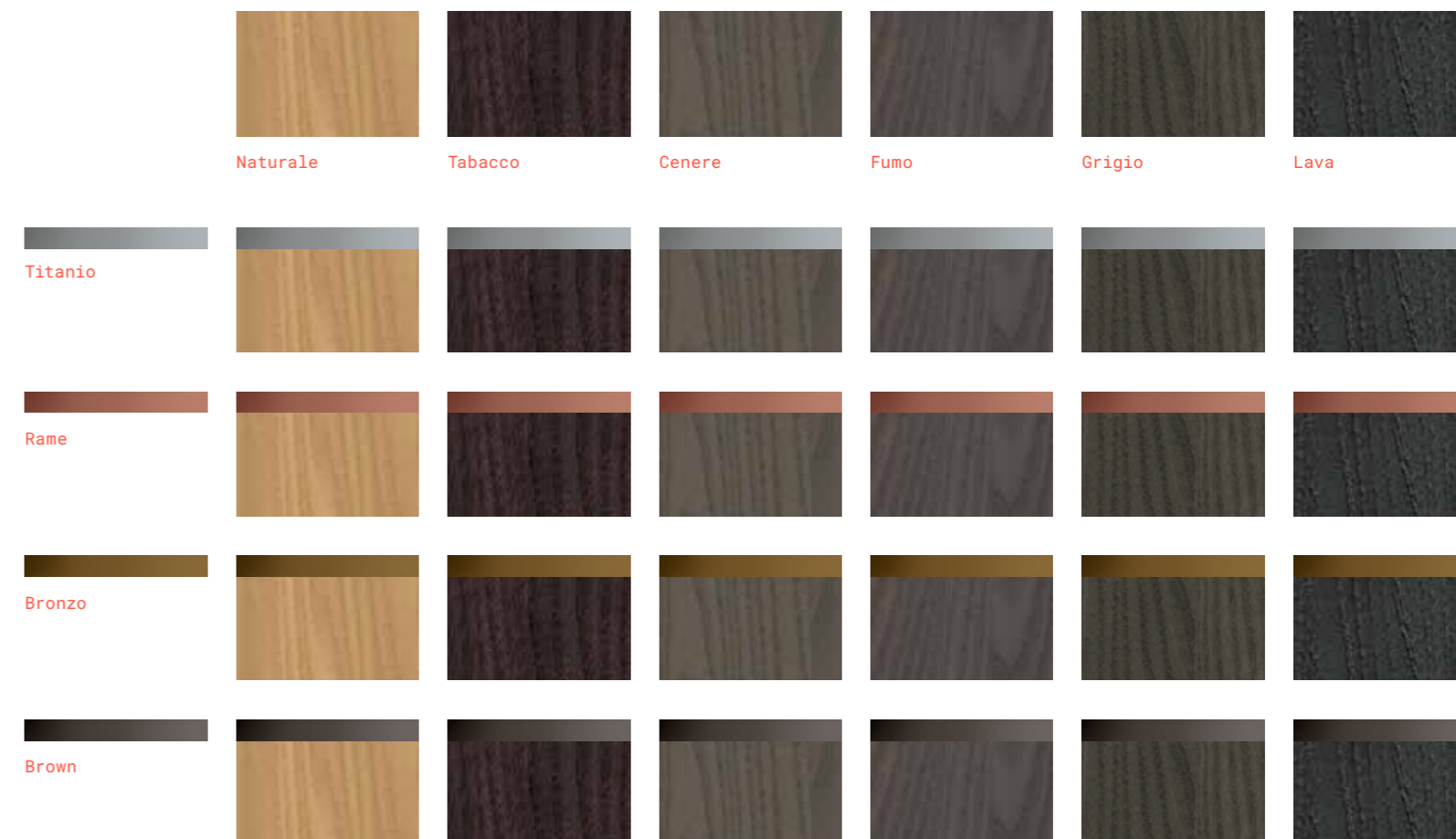

**Questa sezione è un invito a configurare la vostra cucina Meson's con una gamma di materiali dalle eccezionali caratteristiche di qualità e resistenza. Ciascuno proposto in una palette di toni accuratamente selezionata per vestire i volumi della vostra cucina con un carattere e una personalità inconfondibili.**

EN This section is an invitation to configure your Meson's kitchen with a range of materials of exceptional quality and resilience. Each is proposed in a carefully selected range of colours to dress the volumes of your kitchen with unmistakable character and personality.

## Materici / Textured-melamines

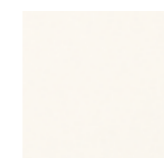

Cera Latte



Cera Vanilla



Cera Grigetto



Cera Toffee



Larice Bistro



Larice Nero

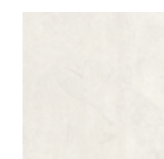

Muro Bianco



Muro Natura

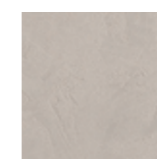

Muro Tortora

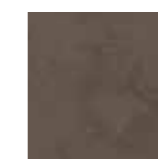

Muro Terra

## Materici e Laminati Smart / Smart Textured-melamines and Laminates



Dune San Paolo



Dune Marsiglia



Dune Tokyo



Rio Bravo

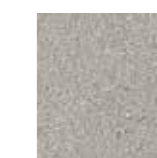

Rio De La Plata



Rio Colorado

## Materici Extra / Extra Textured-melamines



Mica Argento



Mica Ferro



Mica Lapis



Mica Perla



Mica Platino



Noce Chiaro



Noce Caldo

Eucalipto  
Tabacco

Noce cotto

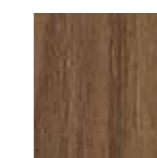

Noce Italia



Quercia Nero

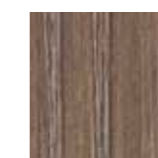

Quercia Bruno

Corteccia  
BiondoCorteccia  
Castano

Piasentina

Laminati Base / Base Laminates



Laminati Omnia / Omnia Laminates

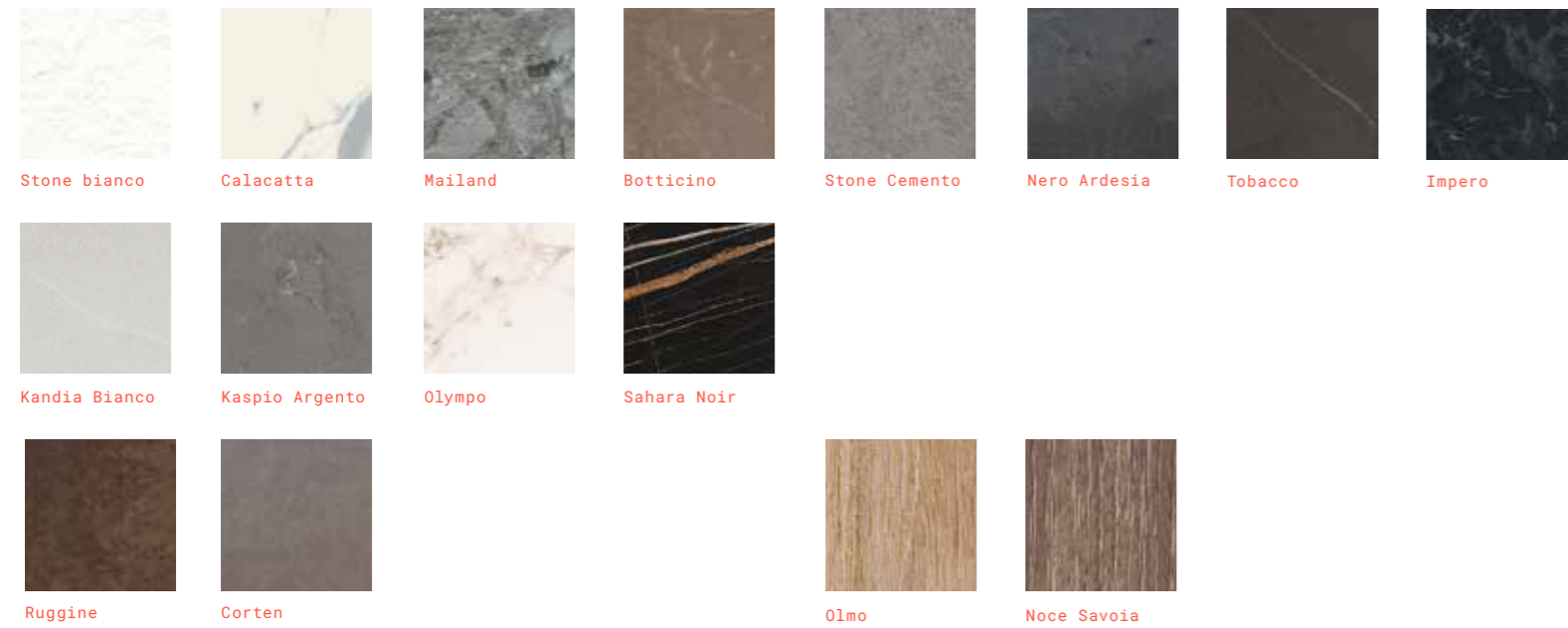

Laminati Onda / Onda Laminates



Laccati Opachi, Lucidi e 3D / Matt, Gloss and 3D Laquers



Laccati Calce / Calce Laquers



Laccati Ossidati / Oxidized Lacquer



Laccati Eccimeri / Eccimeri Lacquered



Fenix NTM®



Vetri Decor / Decor Glass

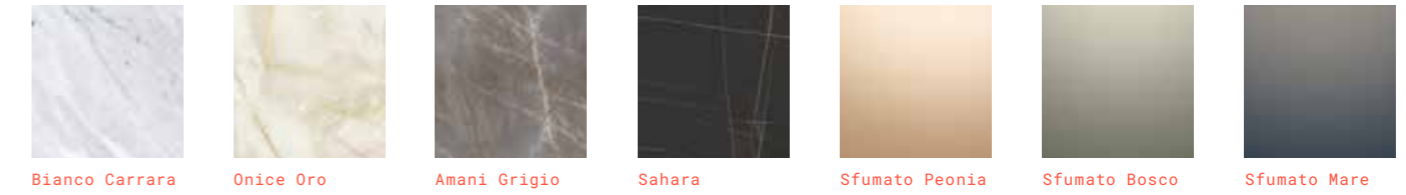

Vetri Acidati e Lucidi / Etched and Gloss Glass



Corian®



Glacier White Antarctica Silver Birch Coca Brown Gravel

Terre



Bianco Perlescente Nero Roma Nero Vite Germania Terra Bruciata

Metallo / Metal



Acciaio AX Satinato Acciaio AX Vintage Acciaio BZ Satinato Bronzo Peltro Ottone

Agglomerati di Marmo / Composite Marbles

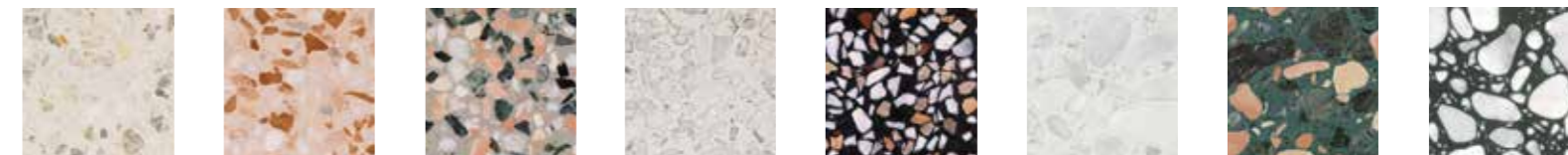

Palazzo Maffei Palazzo Foscari Palazzo Mazzanti Palazzo Reale Palazzo Pisani Palladio Doge Palladio Fenice Palladio Moro

Agglomerati Base / Base Composite Stones



Aosta Salento Monviso Dolomite

Laminam

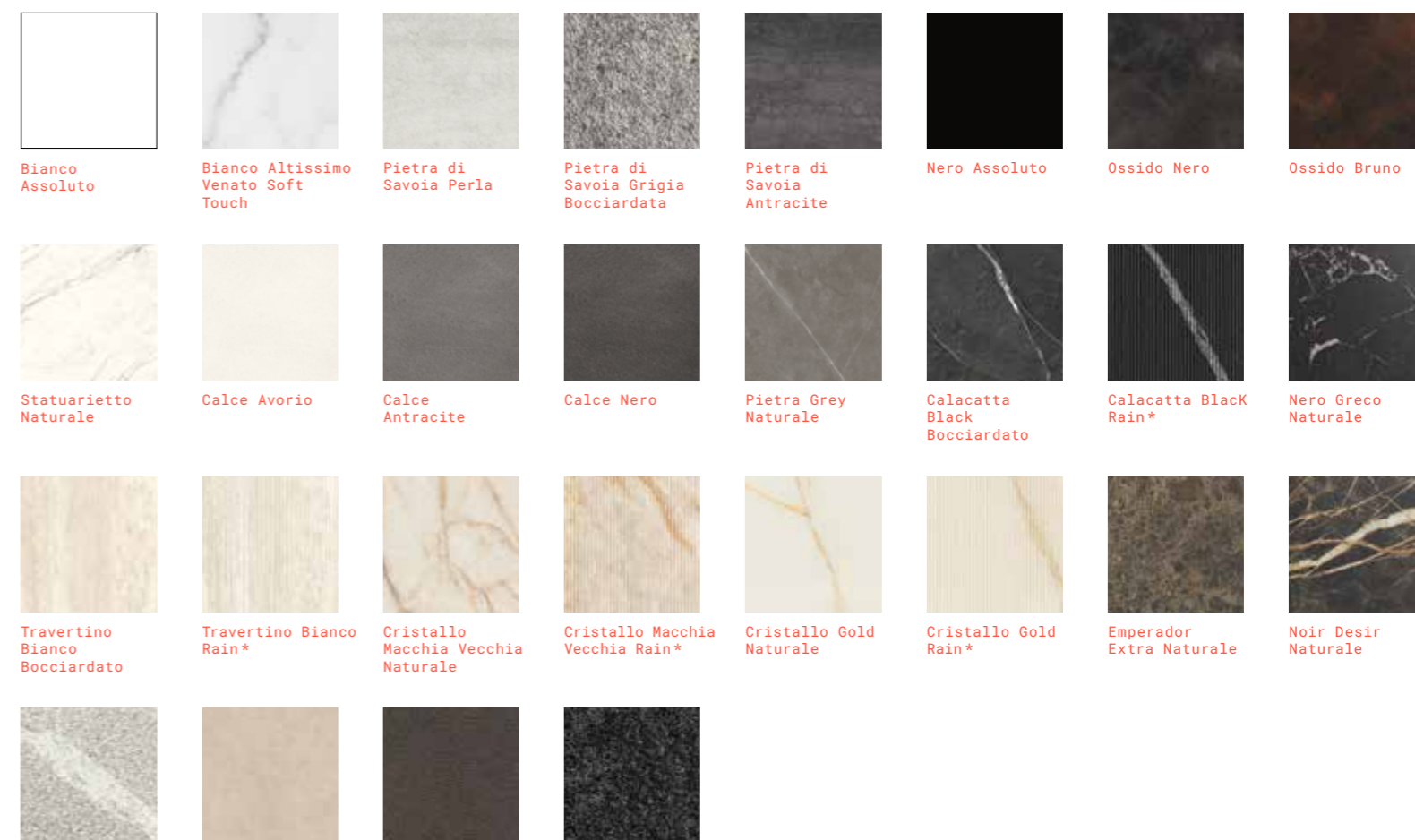

Bianco Assoluto Bianco Altissimo Venato Soft Touch Pietra di Savoia Perla Pietra di Savoia Grigia Bocciardata Pietra di Savoia Antracite Nero Assoluto Ossido Nero Ossido Bruno Statuarietto Naturale Calce Avorio Calce Antracite Calce Nero Pietra Grey Naturale Calacatta Black Bocciardato Calacatta Black Rain\* Nero Greco Naturale Travertino Bianco Bocciardato Travertino Bianco Rain\* Cristallo Macchia Vecchia Naturale Cristallo Macchia Vecchia Rain\* Cristallo Gold Naturale Cristallo Gold Rain\* Emperador Extra Naturale Noir Desir Naturale

\* Solo ante Materia Pura / Materia Pura doors only

## Essenze Premium / Premium Veneer

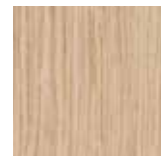

Sabbia



Ambra



Cenere

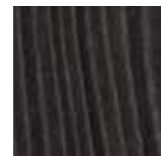

Ossidiana

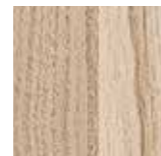

Natura



Noce Tecnico



Fresata Sabbia



Fresata Ambra



Fresata Cenere



Fresata Ossidiana



Scavato Sabbia



Scavato Ambra



Scavato Cenere



Scavato Ossidiana



Tessuto Sabbia



Tessuto Ambra



Tessuto Cenere



Tessuto Ossidiana

## Essenze / Veneer

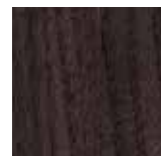
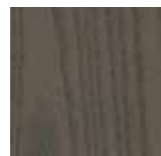

Silva Miele

Silva  
Caramello

Silva Creta

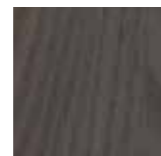

Silva Polvere



Silva Basalto



Silva Pece

Rovere  
Termotrattato

## Rovere Colore / Stained Oak Veneer



Rovere Argilla

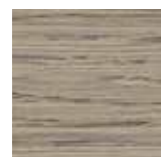

Rovere Cenere



Rovere Grigio



Rovere Carbone

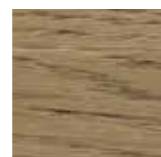

Rovere Avana

## Legno Massello / Solid Wood



Memory Wood

Quercia  
Tavolato

<sup>17</sup> Ogni cucina Meson's è costruita per assicurare un benessere di utilizzo totale e una produzione rispettosa dell'ambiente.

Ogni aspetto riguardante la produzione di una cucina Meson's segue un codice etico che rispecchia la filosofia propria delle persone che ne sono alla guida. Ne discendono una totale dedizione a garantire l'utilizzatore da ogni punto di vista e ad assicurare un utilizzo virtuoso delle risorse del pianeta. Da questo approccio generale è conseguita una naturale coerenza con i requisiti richiesti dai principali enti certificatori.

Tra i marchi di garanzia ottenuti dall'azienda:

- \_la certificazione FSC®, che garantisce la tracciabilità del legno e la provenienza da foreste fruite in modo responsabile, rilasciata dal Forest Stewardship Council®, organizzazione di cui fanno parte gruppi come Greenpeace e WWF, comunità indigene, ricercatori e altre entità coinvolte nel tema deforestazione;
- \_la certificazione CARB2, che garantisce il rispetto dei limiti di emissione di formaldeide richiesti dal California Air Resources Board;
- \_la certificazione di conformità agli standard di qualità ISO 9001:2015 per la progettazione, produzione e commercializzazione di mobili e complementi d'arredo.

<sup>18</sup> Each Meson's kitchen is built to ensure a well-being of total use and an environmentally friendly production.

Every aspect concerning the production of a Meson's kitchen follows an ethical code that reflects the philosophy of the people who lead it. The result is a total dedication to guarantee the user from every point of view and to ensure a virtuous use of the planet's resources. From this general approach derives a natural coherence with the requisites requested by the main certifying bodies.

Among the guarantee marks obtained by the company:

- \_FSC® certification, that guarantees the traceability of the wood and the origin from forests used in a responsible way, issued by the Forest Stewardship Council®, an organization which includes groups such as Greenpeace and WWF, indigenous communities, researchers and other entities involved in the topic deforestation;
- \_CARB2 certification, that guarantees compliance with the formaldehyde emission limits required by the California Air Resources Board;
- \_certification of compliance with ISO 9001:2015 quality standards for the design, production and marketing of furniture and furnishing accessories.

## Legenda Icone / Icons Legend

Maniglie /  
HandlesTavolo /  
TableTop base /  
WorktopMuretto /  
Muretto uprightPiano snack /  
TableBoiserie /  
Wall panellingIsola /  
IslandGamba tavolo /  
Table legColonne /  
Tall unitsTop isola /  
Island worktopBase /  
Base unitElementi a giorno /  
Open compartmentPenisola /  
PeninsulaPensile /  
Wall unitInterno cabine /  
Cabine carcass



D00BC79



---

#### Meson's

#### Servizio clienti

#### International department

#### Credits

---

Meson's Cucine srl  
Via Gradisca, 1  
33087 Pasiano di  
Pordenone  
Pordenone, Italy  
T +39 0434 614911  
www.mesons.it

T +39 0434 614906  
mesons@mesons.it

T +39 0434 614972  
mesons@mesons.it

Direzione artistica:  
M'Studio

Progetto grafico:  
Genny Canton Studio

Styling:  
Daniela Moioli

Foto:  
Alessandro Di Bon  
(pag.16-21 / 30-35 / 44-49)

Render:  
Genny Canton Studio  
(pag.9-12 / 23-27 / 37-41 / 77-109)

Nerokubo  
(pag.51-73 / 134-139)

Render e foto:  
Alessandro Bon  
(pag. 51-73 / 111-133)

Fotolito e stampa:  
Lucegroup.it

Edizione 2026

Questo catalogo è oggetto di copyright®.

Tutti i diritti di immagini e contenuti sono riservati e appartengono agli autori e a Meson's Cucine srl. L'eventuale riproduzione, anche parziale, dei contenuti dovrà essere richiesta e autorizzata per iscritto da Meson's Cucine srl.

L'azienda si riserva di introdurre senza preavviso eventuali modifiche tecnico-costruttive sul prodotto e sulle composizioni presentate.

This catalogue is protected by a copyright®.

All the rights and images contained herein are reserved and belong to the authors and to Meson's Cucine srl. Reproduction, even partial, of the contents must be requested and authorised in writing by Meson's Cucine srl.

Meson's reserves the right to include any technical/constructional changes to the product and the presented arrangements without prior notice.



**MESON'S**